



77V SERIES

Reverse Flow Gas Coalescer

- Single Stage Coalescing Filter
- Vertical Orientation
- ASME Design ("U"/"UM")

Ideal for the removal of solid contaminants and aerosol mists from gas streams 0.3 micron and larger



SUITABLE USES



Air & Gas



Oil & Gas

MEDIA

Accepts single or multiple 336 elements.
**Other size elements available*

COMPATIBLE FILTERS

DynaDep Series, DynaPleat Series, FiberLoc Series, FiberLoc P Series and FiberLoc HT Series

DESIGN PRESSURE

150, 285, 740, 1000 and 1480 PSIG

STD DESIGN TEMP

-20°F to 350°F (-28.8°C to 176.6°C)

AVAILABLE FINISHES

Carbon or Stainless Steel 304 or 316. Also available in C276, AL6XN, 2205, 2507 & Monel 400

ADDITIONAL FEATURES

Single stage coaleser and separator work by moving gas upward through the element from the inside out. Clean gas exits the housing while the coalesced fluid drains via the vessel drain.

Custom sizes, configurations, materials of construction and other options may be available. Please contact Fil-Trek

For more information, e-mail: info@fil-trek.com or visit Fil-Trek.com

77V SERIES

Reverse Flow Gas Coalescer

- Single Stage Coalescing Filter
- Vertical Orientation
- ASME Design



HOUSING SPECIFICATIONS

Inlet/Outlet	Flange
Dirty Drain	1" - 2" NPT
Clean Drain	1" - 2" NPT
Vent	½" NPT on all sizes
Gauges	½" NPT on all sizes
Closure	Swing bolt closure <i>*Limited to pressure class</i>
Headlift	Mechanical Davit on 77V12 and larger Hydraulic Davit on 77V40 and larger
Legs	Skirt
Standard Pressure	150 PSIG <i>*Other pressures available, see table</i>
Standard Temperature	400°F (204°C) <i>*Other temperatures available, see table</i>
Certifications	ASME Section VIII, Div. I U, UM, CE, NB, CRN
Sour Service	Available, please contact
Corrosion Allowance	Available, please contact

PRESSURE & TEMPERATURE DESIGNATION

DESIGNATION	MOC	PSI	TEMP (°F)	ANSI RATING
PT1	CS	285	100	ANSI 150
	SS304/SS316	270		
PT2	CS	200	400	ANSI 150
	SS304/SS316	190		
PT3	CS	740	100	ANSI 300
	SS304/SS316	720		
PT4	CS	635	400	ANSI 300
	SS304/SS316	495		
PT5	CS	1480	100	ANSI 600
	SS304/SS316	1440		

MATERIAL OF CONSTRUCTION

MATERIAL OF CONSTRUCTION	MAX. OPERATING PRESSURE	MAX. DESIGN TEMP
Carbon Steel	150 psi (10.3bar)	400°F (204°C)
304 Stainless Steel	150 psi (10.3bar)	400°F (204°C)
316 Stainless Steel	150 psi (10.3bar)	400°F (204°C)

PRODUCT NOMENCLATURE

S6	77V	32	023	336	14F	PT1	-
MOC	MODEL	HOUSING DIAMETER	# OF FILTERS	FILTER SIZE/ LENGTH	CONNECTION TYPE	DESIGN PRESSURE	OPTIONS
(-) CS S4 SS304 S6 SS316	77V	See Table	See Table	See Table	See Table	150	See "Housing Options"

77V SERIES

Reverse Flow Gas Coalescer

- Single Stage Coalescing Filter
- Vertical Orientation
- ASME Design



HOUSING OPTIONS

*Indicates standard configuration

Configuration Options <i>(at right)</i>	(-) A – Side In/Side Out* D - Same Side In/Out
Finish Options	(-) External paint “National Blue” (CS)* (-) Bead Blast (SS304 and SS316)*
Cover Options**	(-) Swing Bolt (O-Ring Seal)* ANSI Bolted Cover (Gasket Seal) Yoke Cover (O-Ring Seal) Quick Opening Threaded Cover (O-Ring Seal) Quick Opening C-Clamp Cover (O-Ring Seal) Grooved <i>*Based on standard of construction</i> <i>**See page 5-6 for closure options</i>
O-Ring/Gasket Options	O-Ring Options (-) Buna-N* EPDM Viton Silicone Teflon encapsulated Viton Teflon
Filter Support Options	(-) SS304 support post (Std)* SS316 support post
Filter Configuration	Double Open End (std)*
Leg Options	(-) Skirt (Std)* Leg tabs Angle Iron Legs
Accessories	Direct Reading Gauge DP Gauge Safety Relief Valves Vent Valves Drain Valves

A Side in/side out*

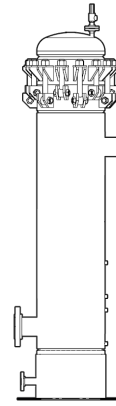

D Side in/Side Out, Same Side

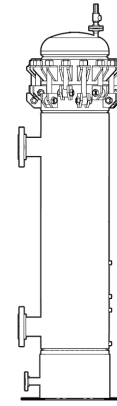

COMPATIBLE FILTERS

DYNADEP SERIES FILTERS

99.98% absolute, 0.3 micron depth gas filter, available in polyester or polypropylene.

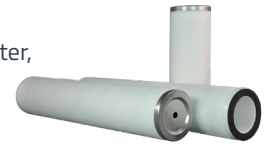

[Click to view DynaDep Series](#)



DYNAPLEAT SERIES FILTERS

99.98% absolute, 0.3 micron pleated gas filter, available in microglass or polyester media

[Click to view DynaPleat Series](#)

FIBERLOC/FIBERLOC HT SERIES FILTERS

98.5% absolute, 0.3 micron depth gas filter, microglass media. Also available for high temperature applications.

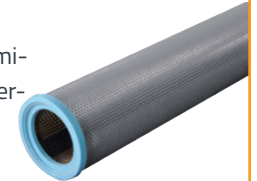

[Click to view FiberLoc Series](#)

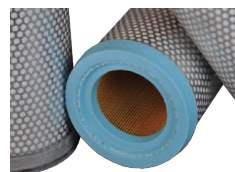

FIBERLOC P SERIES FILTERS

98.5% absolute, 0.3 micron depth gas filter. Microglass media with internal cellulose pleated pre-filter.

[Click to view FiberLoc P Series](#)

77V SERIES

Reverse Flow Gas Coalescer

- Single Stage Coalescing Filter
- Vertical Orientation
- ASME Design



MODEL DIMENSIONAL DETAILS

MODEL	# FILTERS	A	B	C	D	E
77V08-001-336-2F	1	8 ⁵ / ₈ "	28"	74"	24"	90"
77V10-002-336-4F	2	10 ³ / ₄ "	30"	98"	27"	130"
77V12-002-336-4F	2	12 ³ / ₄ "	30"	98"	29"	130"
77V12-003-336-6F	3	12 ³ / ₄ "	30"	100"	29"	130"
77V14-003-336-6F	3	14"	30"	100"	30"	130"
77V14-004-336-6F	4	14"	30"	100"	30"	130"
77V16-005-336-8F	5	16"	30"	100"	32"	132"
77V18-007-336-8F	7	18"	30"	100"	34"	132"
77V20-008-336-8F	8	20"	30"	100"	36"	132"
77V22-011-336-8F*	11	22"	30"	100"	40"	132"
77V24-013-336-10F	13	24"	30"	112"	44"	134"
77V26-016-336-12F	16	26"	30"	114"	46"	148"
77V28-019-336-12F	19	28"	30"	114"	48"	148"
77V30-021-336-14F	21	30"	34"	120"	50"	156"
77V32-023-336-14F	23	32"	34"	120"	52"	156"
77V34-028-336-16F	28	34"	34"	120"	54"	156"
77V36-031-336-16F	31	36"	34"	120"	56"	156"

*Only available in swing bolt closure up to limited pressure, please contact. Specifications above do not include corrosion allowance and are for 336 elements and are reference only. Available in additional sizes up to 72' diameter. For sizing information for other element sizes please contact Fil-Trek. All quotes are complete with certified drawing which indicate accurate dimensions and weight.

A Side in/side out*

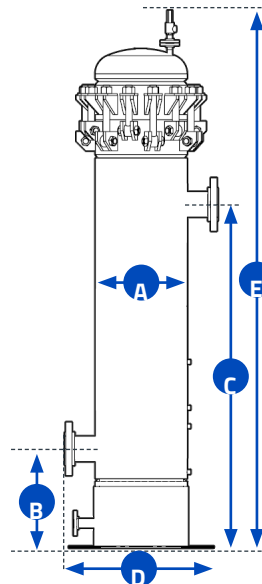

CHART LEGEND

- A** OUTSIDE DIAMETER
- B** FLOOR TO INLET
- C** FLOOR TO OUTLET
- D** FACE TO FACE
- E** OVERALL HEIGHT

77V SERIES

Reverse Flow Gas Coalescer

- Single Stage Coalescing Filter
- Vertical Orientation
- ASME Design



CLOSURE AND QUICK OPENING COVER OPTIONS

Fil-Trek designs and fabricates a variety of closure and quick opening cover options to accommodate strict applications and requirements. All materials of construction are in accordance with ASME specifications and manufacturing complies with the applicable rules of the ASME Code for Pressure Piping and with the ASME Boiler and Pressure Vessel Code.

HINGED COVER

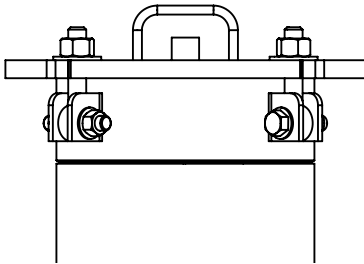

The most economical quick opening closure offered for fabricated strainers with nominal pressure applications. The swing bolt hinged cover uses an O-ring to seal. Easy to open by quickly and easily by loosening the swing bolts until they clear the holding lugs and swinging the head open on its hinge.

MECHANICAL DAVIT ASSEMBLY

Our mechanical davit assembly makes it easy for the operator to open and swing the cover away to facilitate basket or screen removal for cleaning. It is used primarily for larger strainers where cover removal is difficult and heavy. This is the most inexpensive alternative to quick release covers, especially when operating conditions require a bolted cover. Available for swing bolt and ANSI closures.

**Hydraulic davit head lift also available.

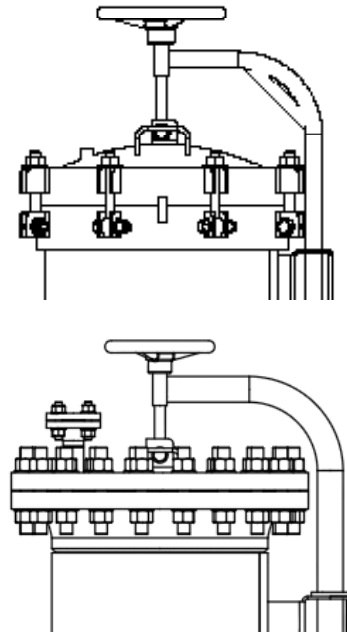

77V SERIES

Reverse Flow Gas Coalescer

- Single Stage Coalescing Filter
- Vertical Orientation
- ASME Design



THREADED HINGED COVER

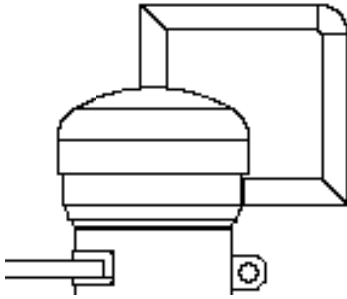

The quick open threaded hinged closure uses a cap fastened to a hub and is welded to the strainer body. The female cap is threaded onto the male hub using O-rings to seal. The O-ring prevents corrosion of the closure threads and provides a long, trouble free service. The threaded cover can be used for both nominal and high pressure applications. Available in both vertical and horizontal configurations.

YOKE CLOSURE

The Yoke hinged cover is a true ANSI rated closure and uses an O-ring seal. Used primarily on high pressure applications, it is available for 150#, 300#, 600#, 900# and 1500# ANSI ratings with a wide range of operating aids, ranging from a single lever chain and sprocket drive to completely automated.

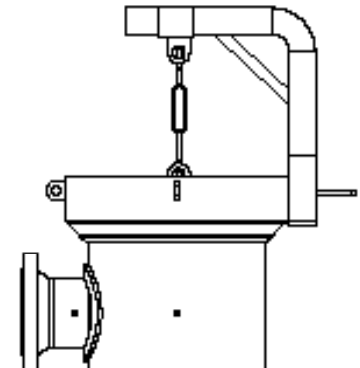

CLOSURE COMPARISON

	COVER TYPE			
	HINGED COVER	MECHANICAL DAVIT	THREADED COVER	YOKE CLOSURE
COST	Low	Moderate	High	High
QUICK OPENING ABILITY	Good	Fair	Best	Best
LOW PRESSURE APPLICATIONS	X	X	-	-
NOMINAL PRESSURE APPLICATIONS	X	X	X	X
HIGH PRESSURE APPLICATIONS	-	X	X	X

77V SERIES

Reverse Flow Gas Coalescer

- Single Stage Coalescing Filter
- Vertical Orientation
- ASME Design



GAS HOUSING SIZING WORKSHEET

Please use the following worksheet to enter as much detail as possible about the gas application you are sizing for. The minimum requirement we need to help size will be the areas marked with an '*':

Operating Conditions

Name of Gas* _____	Name of Liquid Present _____
Max. Operating Flow Rate* _____	@ _____ Pressure (PSIG)
Gas Specific Gravity (Air = 1)* _____	OR Mole Weight/Composition _____
Type of System or Location in Process* _____	Dry? <input type="checkbox"/> Wet? <input type="checkbox"/>
Min. Operating Pressure (PSIG)* _____	Max. Operating Pressure (PSIG) _____
Min. Operating Temperature (F) _____	Max. Operating Temperature (F)* _____
Amount of Liquids Present (GPD) _____	Specific Gravity (Water = 1) _____
Amount of Particulate Present (Parts per 100 scf) _____	Name of Particulate _____
Max. Allowable Clean Pressure Drop _____	(Standard = 2 PSID Flange to Flange)

Mechanical Data

Design Pressure Min.* _____ Max.* _____	Design Temperature Min.* _____ Max.* _____
ASME Code Required?* _____	Sour Service? <input type="checkbox"/> Acid Service? <input type="checkbox"/>
If YES, Pressure (PSI) _____ Temp (F) _____	Corrosion Allowance (in) _____
Fire Safe Service _____	(ie All Connections/Closures Flanged?) _____
Inlet/Outlet Type Flanged <input type="checkbox"/> Threaded <input type="checkbox"/>	Other (Please specify) _____
Type/ANSI Rating of Flanges (#) _____	Face RF <input type="checkbox"/> RTJ <input type="checkbox"/> Type SO <input type="checkbox"/> WN <input type="checkbox"/> LWN <input type="checkbox"/>
Vessel MOC CS <input type="checkbox"/> SS304 <input type="checkbox"/> SS316 <input type="checkbox"/>	Other (Please specify) _____
Internals MOC CS <input type="checkbox"/> SS304 <input type="checkbox"/> SS316 <input type="checkbox"/>	Other (Please specify) _____

Other Details
