

VESSEL B

NOZZLE SCHEDULE			
MARK	QTY	SIZE / RATING	DESCRIPTION
N1	1	12" 150# RFSO	INLET
N2	1	12" 150# RFSO	OUTLET
N3	2	1/2" 3000# NPT	PRESSURE GAUGE
N4	2	1/2" 3000# NPT	VENT
N5	1	2" 3000# NPT	CLEAN DRAIN
N6	1	2" 3000# NPT	DIRTY DRAIN

VESSEL DESIGN CONDITIONS			
CODE: ASME SECTION VIII DIV. 1, 2017 EDITION			
M.A.W.P.:	150 PSI @ 400°F	M.D.M.T.:	-50° F @ 150 PSI
M.A.W.P.:	FV PSI @ 400°F		
CORROSION ALLOWANCE:	NONE	HYDROTEST PRESS:	210 PSI
STAMP:	U	SERVICE:	LIQUID NON LETHAL
PWHT:	N/A	RADIOGRAPHY:	N/A
MATERIAL:	SS316	GASKET:	BUNA-N

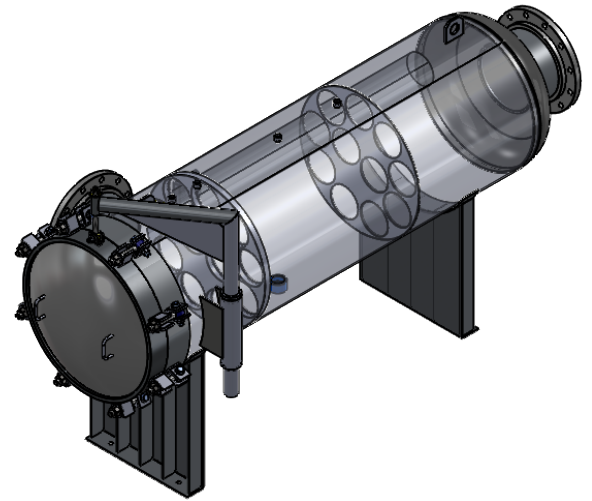

NOTES:

1. DRY WEIGHT: 1362.38 LBS
2. SHIPPING WEIGHT: 1350 LBS
3. FLOODED WEIGHT: 3345 LBS
4. VESSEL VOLUME: 35.95 C.F.
5. VESSEL WILL HOUSE (QTY=11) 6"OD x 60" ULTRA FLOW CARTRIDGE.

APPROVED WITH MARK-UPS <input type="checkbox"/>		APPROVED <input type="checkbox"/>	
<p>THIRD ANGLE PROJECTION</p> <p>TOLERANCES-UNLESS OTHERWISE NOTED</p> <p>DECIMAL .X = ±.1" .XX = ±.02" .XXX = ±.005"</p> <p>FRACTIONAL = ±1/8"</p> <p>ANGULAR = ± 1°</p> <p>MAX. MACHINED SURFACE FINISH 125/√</p>	<p>FIL-TREK CORPORATION</p> <p>55 Stafford Court Cambridge, Ontario N1T 1B3 Canada</p> <p>Phone: (519) 623-7448 Fax: (519) 623-8807 Email: info@fil-trek.com Website: www.fil-trek.com</p>		
	<p>THIS DRAWING IS THE PROPERTY OF 'FIL-TREK CORPORATION' AND MUST NOT BE COPIED OR USED IN ANY WAY DETRIMENTAL TO THE CORPORATION</p> <p>EQUIPMENT: UFH SERIES (CARTRIDGE FILTER VESSEL)</p> <p>MODEL NO: S6UFH28-11-60-12F-150</p> <p>CUSTOMER:</p>		
PARENT: NEW DESIGN	DRAWN: JN	DATE: 19/02/19	SCALE: NTS
CHK'D: NV	SERIAL No. V10718	Part. No. 001012-00085	REV. No. 0