

NOZZLE SCHEDULE			
MARK	QTY	SIZE / RATING	DESCRIPTION
N1	1	8" 150# RFSO	INLET
N2	1	8" 150# RFSO	OUTLET
N3	2	1/2" 3000# NPT	PRESSURE GAUGE
N4	1	1/2" 3000# NPT	VENT
N5	1	2" 3000# NPT	CLEAN DRAIN
N6	1	1/2" 3000# NPT	DIRTY DRAIN

VESSEL DESIGN CONDITIONS	
CODE:	ASME CODE SECTION VIII DIV. 1, 2017 EDITION
M.A.W.P.:	150 PSI @ 400°F
M.D.M.T.:	-50° F @ 150 PSI
M.A.W.P.:	FV PSI @ 400°F
CORROSION ALLOWANCE:	NONE
HYDROTEST PRESS:	210 PSI
STAMP:	U
SERVICE:	LIQUID NON LETHAL
PWHT:	N/A
RADIOGRAPHY:	N/A
MATERIAL:	SS316
GASKET:	BUNA

- NOTES:
1. VESSEL WILL HOUSE (QTY=8) SIZE 2 BASKETS.
 2. VESSEL DRY WEIGHT: 1016.73 LBS.
 3. SHIPPING WEIGHT: 1300 LBS.
 4. FLOODED WEIGHT: 2025 LBS.
 5. VESSEL VOLUME: 14.45 FT³

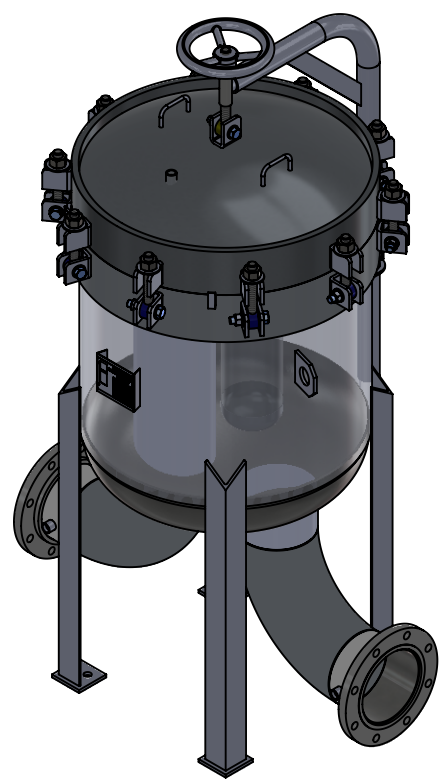
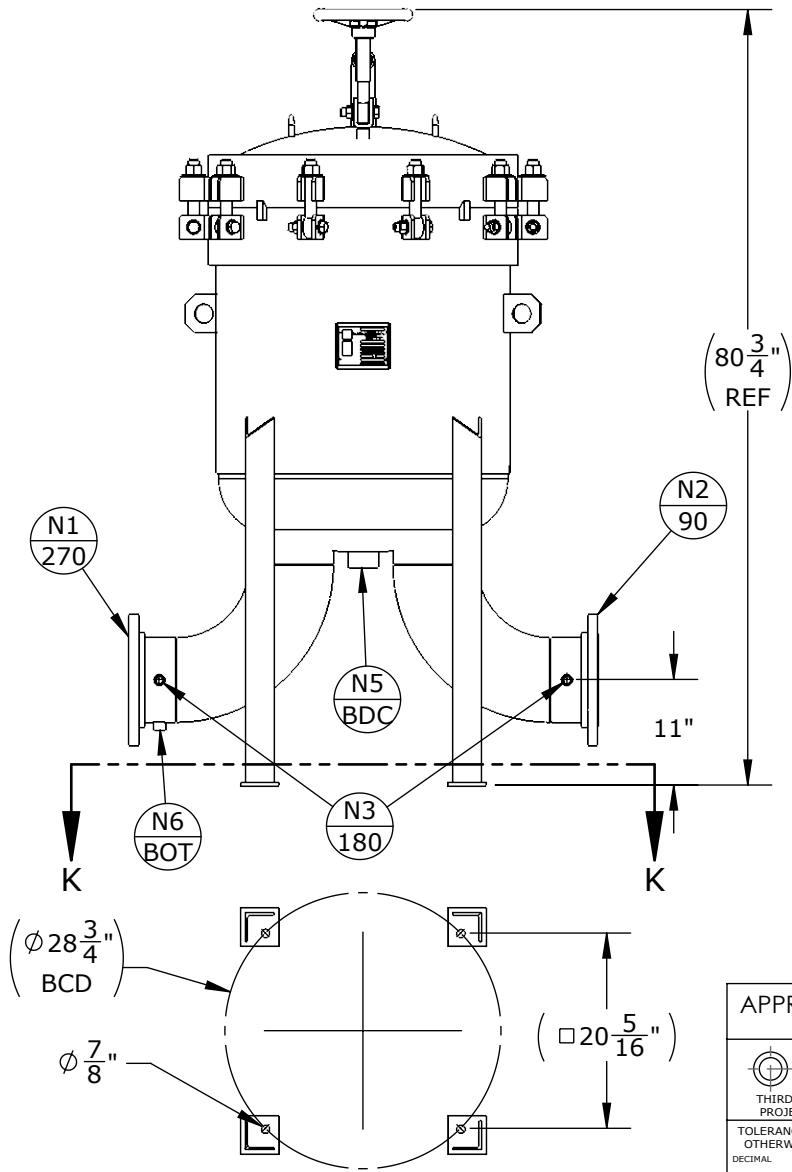

SECTION K-K
SCALE 1 : 20

APPROVED WITH MARK-UPS <input type="checkbox"/>		APPROVED <input type="checkbox"/>	
<p>THIRD ANGLE PROJECTION</p> <p>TOLERANCES-UNLESS OTHERWISE NOTED</p> <p>DECIMAL .X = ±.1" .XX = ±.02" .XXX = ±.005"</p> <p>FRACTIONAL = ±1/8"</p> <p>ANGULAR = ± 1°</p> <p>MAX. MACHINED SURFACE FINISH 125/√</p>	<p>FIL-TREK CORPORATION</p> <p>55 Stafford Court Cambridge, Ontario N1T 1B3 Canada</p> <p>Phone: (519) 623-7448 Fax: (519) 623-8807 Email: info@fil-trek.com Website: www.fil-trek.com</p>		
	<p>THIS DRAWING IS THE PROPERTY OF 'FIL-TREK CORPORATION' AND MUST NOT BE COPIED OR USED IN ANY WAY DETRIMENTAL TO THE CORPORATION</p> <p>EQUIPMENT: BMB SERIES (BAG FILTER VESSEL)</p> <p>MODEL NO: S6BMB30-812-8F-150</p> <p>CUSTOMER:</p>		
PARENT: NEW DESIGN	DRAWN: JN	DATE: 13/03/19	SERIAL No. Part No. 002005-00041
CHK'D: NV	SCALE: NTS		REV. No. 0