

NOZZLE SCHEDULE			
MARK	QTY	SIZE / RATING	DESCRIPTION
N1	1	8" 150# RFSO	INLET
N2	1	8" 150# RFSO	OUTLET
N3	2	1/2" 3000# NPT	PRESSURE GAUGE
N4	1	1/2" 3000# NPT	VENT
N5	1	2" 3000# NPT	CLEAN DRAIN
N6	1	1/2" 3000# NPT	DIRTY DRAIN

VESSEL DESIGN CONDITIONS	
CODE:	ASME SECTION VIII DIV. 1, 2017 EDITION
M.A.W.P.:	150 PSI @ 400°F
M.D.M.T.:	-50° F @ 150 PSI
M.A.W.P.:	FV PSI @ 400°F
CORROSION ALLOWANCE:	NONE
HYDROTEST PRESS:	210 PSI
STAMP:	U
SERVICE:	LIQUID, NON LETHAL
PWHT:	N/A
RADIOGRAPHY:	N/A
MATERIAL:	SS316
GASKET:	BUNA-N

NOTES:

1. VESSEL WILL HOUSE (QTY 12) SIZE 2 SS316 BASKETS
2. DRY WEIGHT: 1111.16 LBS
3. FLOODED WEIGHT: 2025 LBS
4. SHIPPING WEIGHT: 1200 LBS
5. VESSEL VOLUME: 19 C.F.

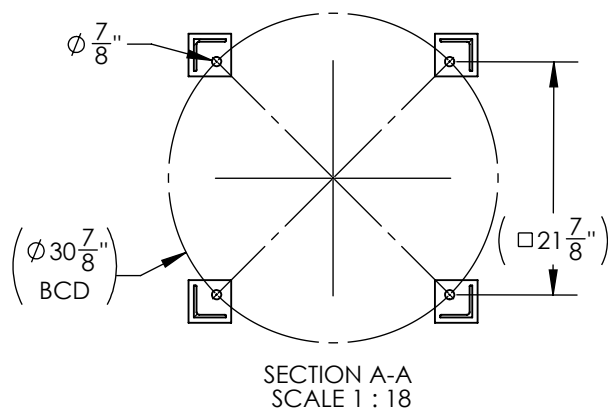
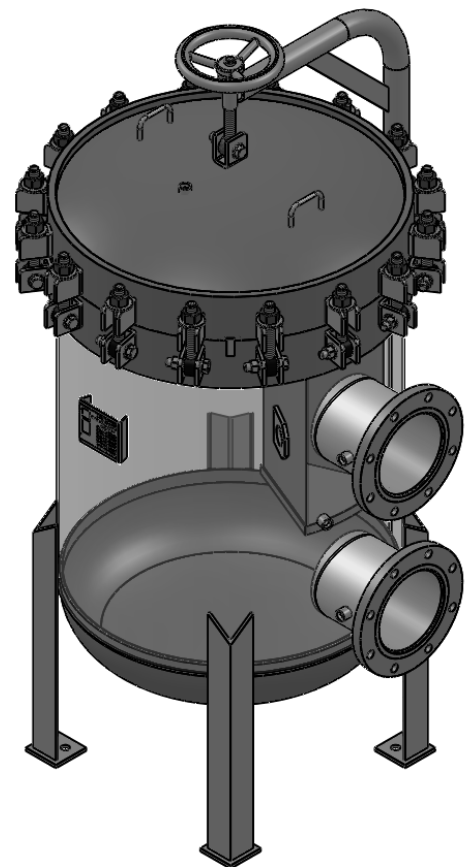
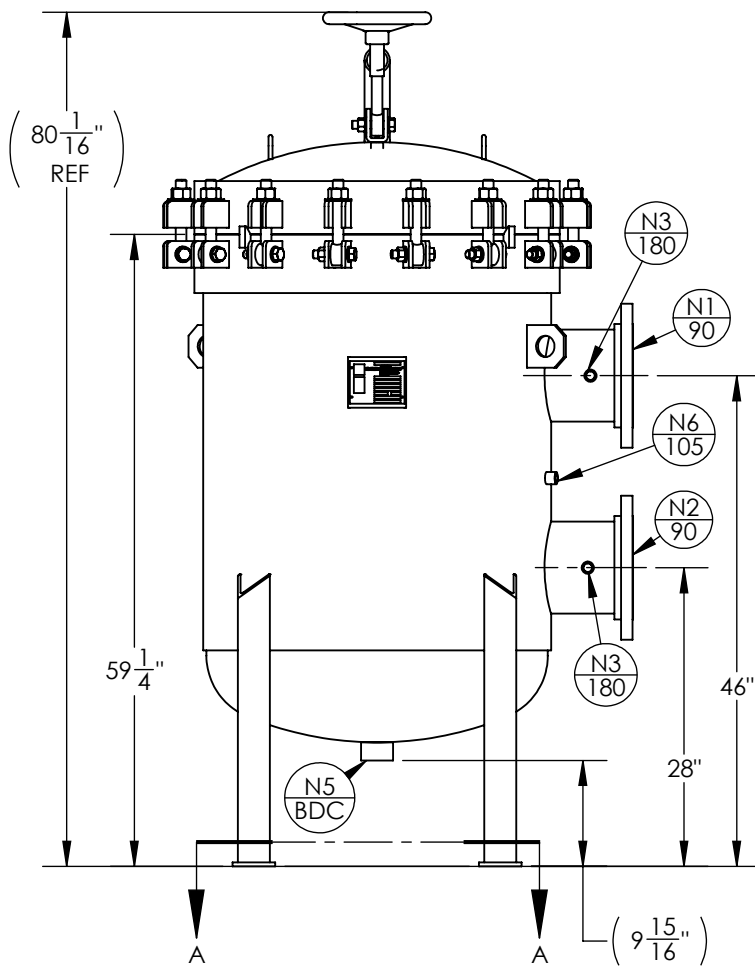

APPROVED WITH MARK-UPS <input type="checkbox"/>		APPROVED <input type="checkbox"/>	
 THIRD ANGLE PROJECTION	 FIL-TREK CORPORATION		
	55 Stafford Court Cambridge, Ontario N1T 1B3 Canada		Phone: (519) 623-7448 Fax: (519) 623-8807 Email: info@fil-trek.com Website: www.fil-trek.com
THIS DRAWING IS THE PROPERTY OF 'FIL-TREK CORPORATION' AND MUST NOT BE COPIED OR USED IN ANY WAY DETRIMENTAL TO THE CORPORATION			
EQUIPMENT:		LP SERIES (BAG FILTER VESSEL)	
MODEL NO:		S6LP32-1212-8F-DA-150	
CUSTOMER:			
PARENT: NEW DESIGN	DRAWN: JJJ	DATE: 10/07/2018	SERIAL No. Part No. 002004-00398
	CHK'D: JN	SCALE: NTS	REV. No. 0