

NOZZLE SCHEDULE			
MARK	QTY	SIZE / RATING	DESCRIPTION
N1	1	4" 150# RFSO	INLET
N2	1	4" 150# RFSO	OUTLET
N3	2	1/2" 3000# NPT	PRESSURE GAUGE
N4	1	1/2" 3000# NPT	VENT
N5	1	1" 150# NPT	CLEAN DRAIN
N6	1	1" 150# NPT	DIRTY DRAIN
VESSEL DESIGN CONDITIONS			
CODE: BEST COMMERCIAL PRACTICE			
M.A.W.P.:	150 PSI @ 400°F	GASKET:	BUNA
M.A.W.P.:	FV PSI @ 400°F		
M.D.M.T.:	-50° F @ 150 PSI		
HYDROTEST PRESS:	210 PSI		
MATERIAL:	SS 316		

NOTES:

1. VESSEL DRY WEIGHT: **353.48** LBS.
2. SHIPPING WEIGHT: **450** LBS.
3. FLOODED WEIGHT: **850** LBS.
4. VESSEL VOLUME: **8.06** CU. FT.
5. VESSEL WILL HOUSE (QTY=32) 2.5"OD x 30" LG CARTRIDGE SOE 222/ FIN END (E5).

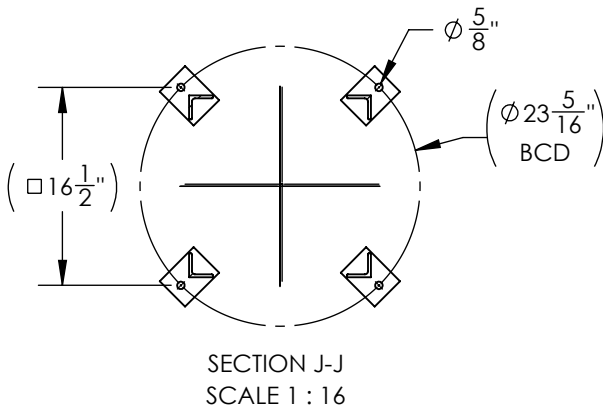
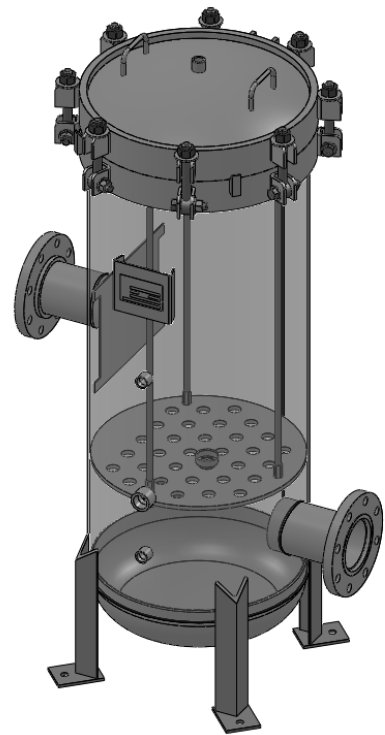
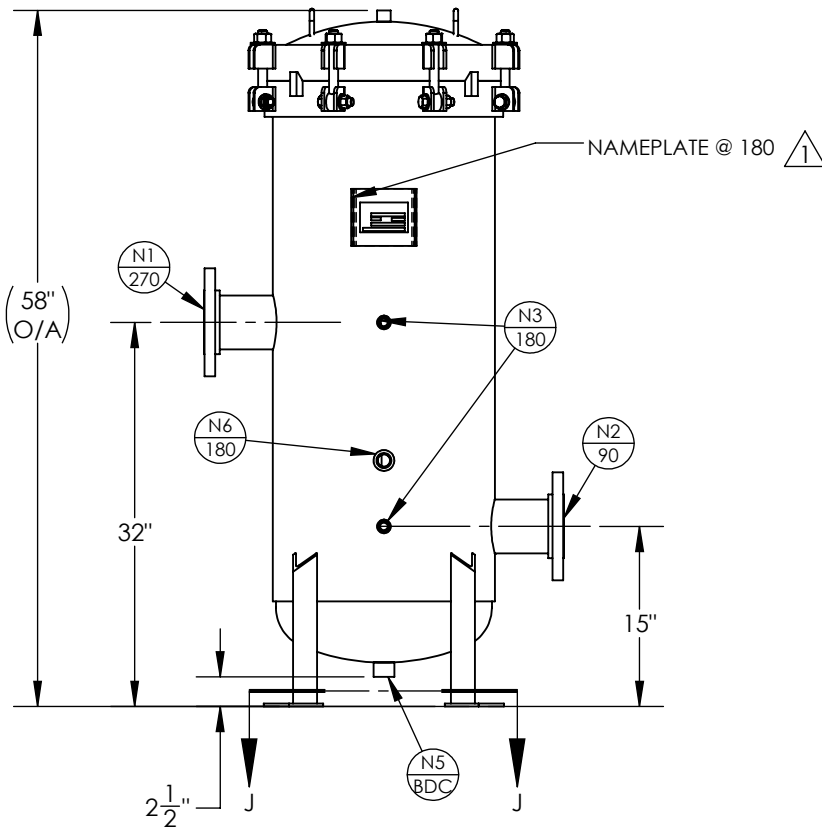

**REVISED DESIGN ONLY APPLIES TO VESSELS 1-3**

1	ROTATED NAMEPLATE AND HINGE 180°	03/07/2018	JN
REV.	DESCRIPTION	DATE	DRW'N

APPROVED WITH MARK-UPS  APPROVED

<p>THIRD ANGLE PROJECTION</p> <p>TOLERANCES-UNLESS OTHERWISE NOTED</p> <p>DECIMAL .X = ±.1" .XX = ±.02" .XXX = ±.005"</p> <p>FRACTIONAL = ±1/8"</p> <p>ANGULAR = ± 1°</p> <p>MAX. MACHINED SURFACE FINISH 125/√</p>	<p><b>FIL-TREK CORPORATION</b></p> <p>55 Stafford Court Cambridge, Ontario N1T 1B3 Canada</p> <p>Phone: (519) 623-7448 Fax: (519) 623-8807 Email: info@fil-trek.com Website: www.fil-trek.com</p>			
	<p>THIS DRAWING IS THE PROPERTY OF 'FIL-TREK CORPORATION' AND MUST NOT BE COPIED OR USED IN ANY WAY DETRIMENTAL TO THE CORPORATION</p> <p>EQUIPMENT: EGL SERIES (CARTRIDGE FILTER VESSEL)</p> <p>MODEL NO: S6EGL18-032-4-4F-E5-150</p> <p>CUSTOMER: DESALITECH</p>			
PARENT:	DRAWN: JN	DATE: 23/05/2018	SERIAL No. Part No. 001022-00220	REV. No. 1
	CHK'D: JJJ	SCALE: NTS		