

NOZZLE SCHEDULE			
MARK	QTY	SIZE / RATING	DESCRIPTION
N1	1	3" 150# RFWN	INLET
N2	1	3" 150# RFWN	OUTLET
N3	2	1/2" 3000# NPT	PRESSURE GAUGE
N4	1	1/2" 3000# NPT	VENT
N5	1	1/2" 3000# NPT	CLEAN DRAIN
N6	-		DIRTY DRAIN

VESSEL DESIGN CONDITIONS	
CODE:	ASME SECTION VIII DIV. 1, 2021 EDITION
M.A.W.P.:	225 PSI @ 200°F
M.D.M.T.:	-20° F @ 225 PSI
M.A.W.P.:	FV PSI @ 200°F
CORROSION ALLOWANCE:	NA
HYDROTEST PRESS:	293 PSI
STAMP:	UM
SERVICE:	UNK. NON-LETHAL
PWHT:	N/A
RADIOGRAPHY:	N/A
MATERIAL:	SS316
GASKET:	SPIRAL WOUND

NOTES:

- DRY WEIGHT: 73 LBS
- SHIPPING WEIGHT: 160 LBS
- VESSEL VOLUME: 0.1 CU. FT.
- FLOODED WEIGHT: 90 LBS
- INTERNALS: 2" OD PERF TUBE (1/8"H ON 3/16"C) - 400 MESH
- ELECTROPOLISHED IN/OUT

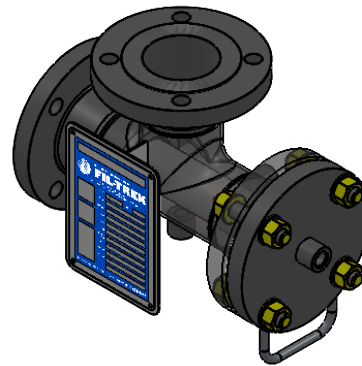
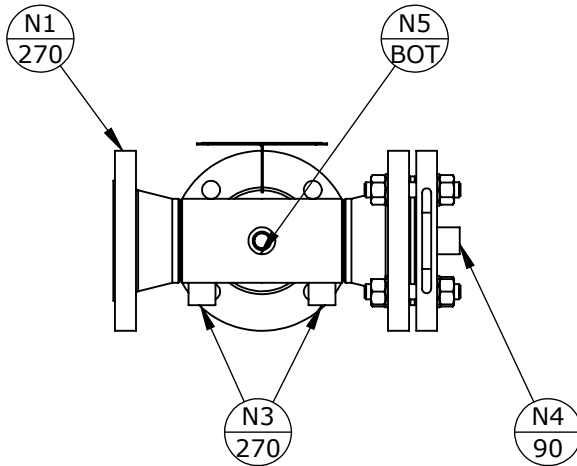
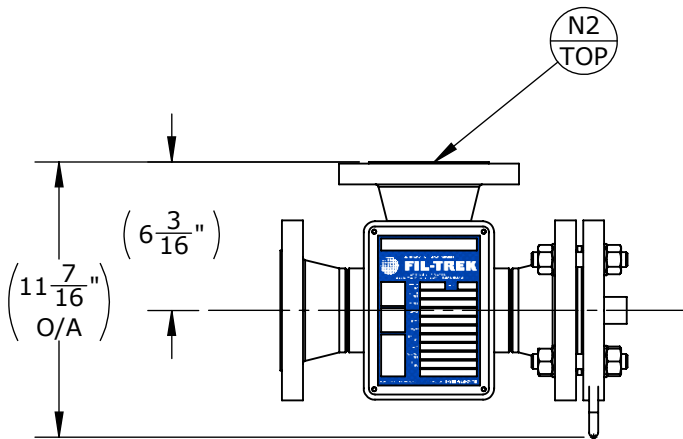

REVISIONS

ZONE	REV.	DESCRIPTION	DATE	APPROVED
B1	1	CHANGE PERF/MESH TUBE	2023-04-05	NRR

THIRD ANGLE PROJECTION
 TOLERANCES-UNLESS OTHERWISE NOTED
 DECIMAL .X = ±.1"
 .XX = ±.02"
 .XXX = ±.005"
 FRACTIONAL = ±1/8"
 ANGULAR = ± 1°
 MAX. MACHINED SURFACE FINISH 125/√

FIL-TREK CORPORATION
 55 Stafford Court
 Cambridge, Ontario
 N1T 1B3
 Canada
 Phone: (519) 623-7448
 Fax: (519) 623-8807
 Email: info@fil-trek.com
 Website: www.fil-trek.com

THIS DRAWING IS THE PROPERTY OF 'FIL-TREK CORPORATION' AND MUST NOT BE COPIED OR USED IN ANY WAY DETRIMENTAL TO THE CORPORATION

EQUIPMENT: 96 SERIES (T STRAINER HOUSING)
 MODEL NO: S696D2B-3F-225-EP

PARENT: NONE	DRAWN: NRR	DATE: 2023-04-04	SERIAL No. V13572	Part No. 003003-00190	REV. No. 1
	CHK'D:	SCALE: NTS			