

NOZZLE SCHEDULE			
MARK	QTY	SIZE/RATING	DESCRIPTION
N1	1	2" 150# NPT	INLET
N2	1	2" 150# NPT	OUTLET
N3	2	1/2" 3000# NPT	PRESS GA
N4	1	1/2" 3000# NPT	VENT
N5	1	1/2" 3000# NPT	CLEAN DRAIN
N6	1	1/2" 3000# NPT	DIRTY DRAIN

VESSEL DESIGN CONDITIONS	
CODE: BEST COMMERCIAL PRACTICE	
M.A.W.P. 150PSI @ 250 °F	M.D.M.T. -20 °F @ 150PSI
CORROSION ALLOW.: NONE	HYDROTEST PRESS: 150PSI
STAMP: NONE	SERVICE: NON LETHAL
PWHT: N/A	RADIOGRAPHY: N/A
MATERIAL: SS304	GASKET: BUNA-N

DRY WEIGHT: 37.90 #'s
 FLOODED WEIGHT: 82 #'s
 SHIPPING WEIGHT: 100 #'s
 VESSEL VOLUME: 0.49 C.F.

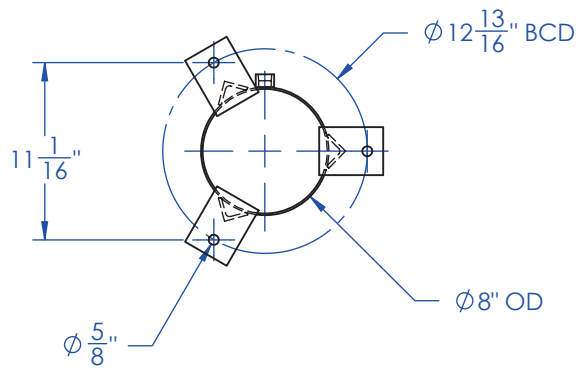
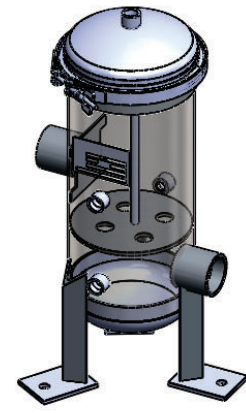
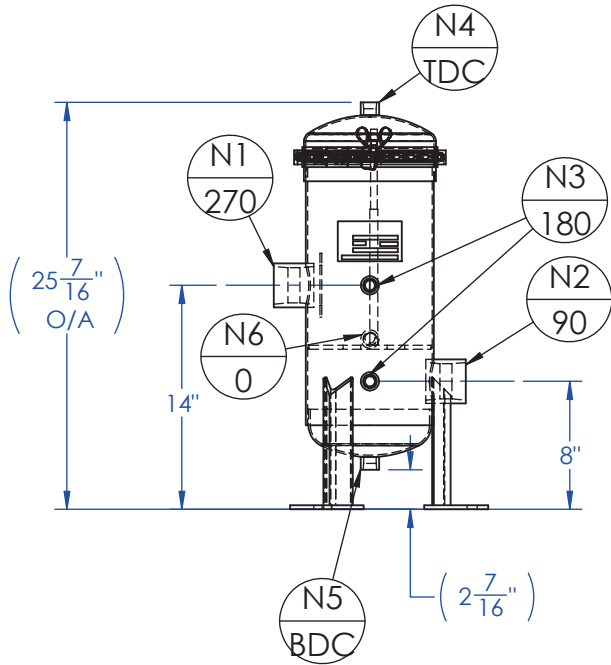

NOTES:
 • VESSEL WILL HOUSE (QTY=4) 2.75" OD x 10" LG CARTRIDGES.

REV.	DATE	REVISION	DRAWN	APP'D
 FIL-TREK CORPORATION CAMBRIDGE ONTARIO - CANADA www.fil-trek.com • Tel: 519.623.7448 • Fax: 519.623.8807				
<small>THIS DRAWING IS THE PROPERTY OF FIL-TREK CORPORATION AND MUST NOT BE COPIED OR USED IN ANY WAY DETRIMENTAL TO THE CORPORATION.</small>				
EQUIPMENT:		CARTRIDGE FILTER HOUSING (EF SERIES)		
MODEL NO.:		S4EF08-004-1-2P-VB		
PARENT: NONE		DATE: SEPT 28 2010	JOB No.	DWG. No.
PAGE: 1 OF 4		CHK'D: PT	SCALE: NTS	V-5068
				002-0017
				0