

FIL-TREK 98 SERIES SELF-CLEANING STRAINER RENTAL UNIT

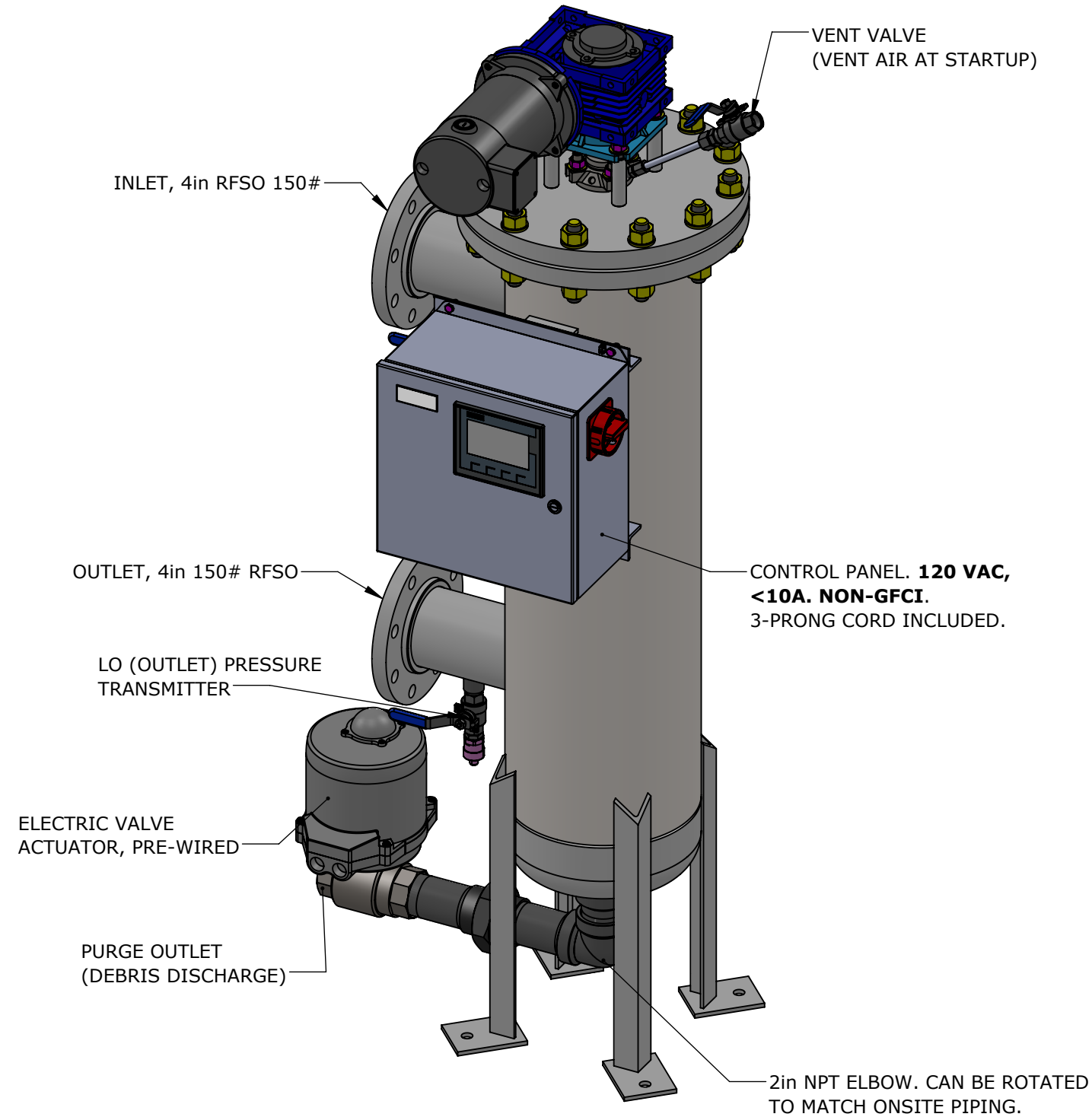
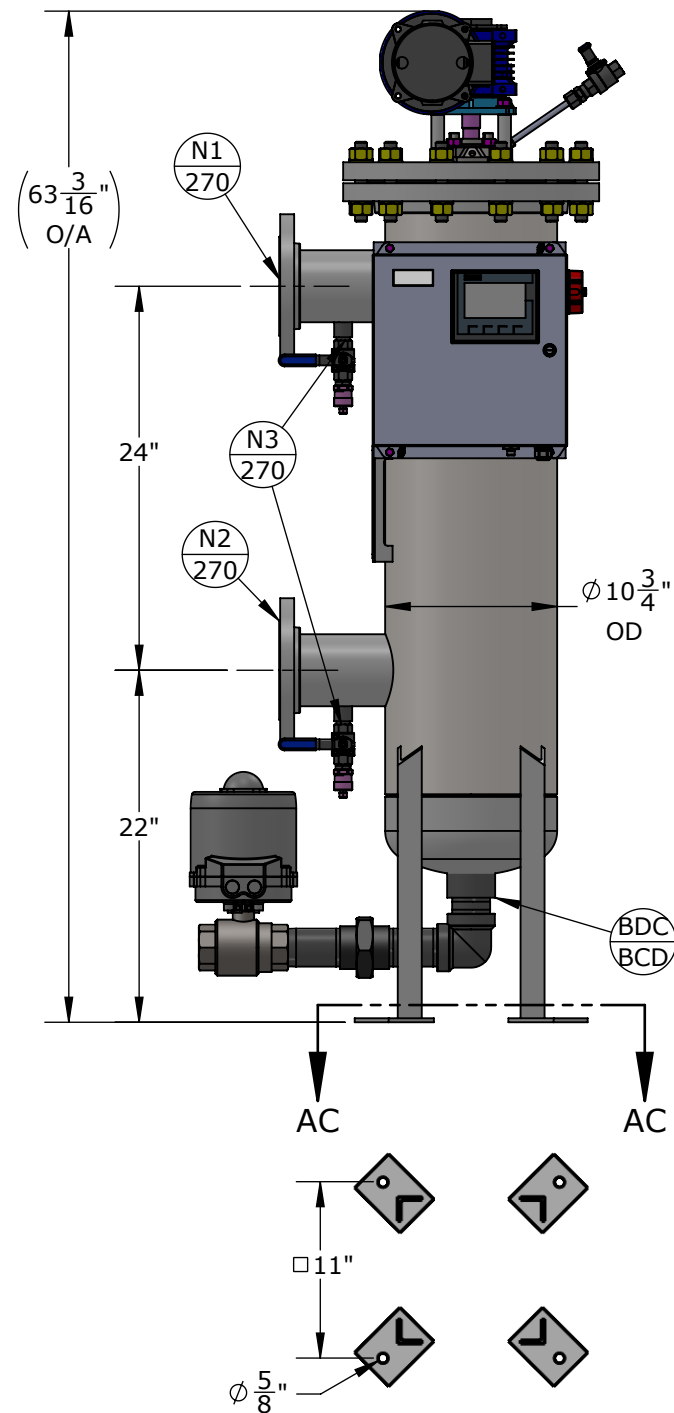
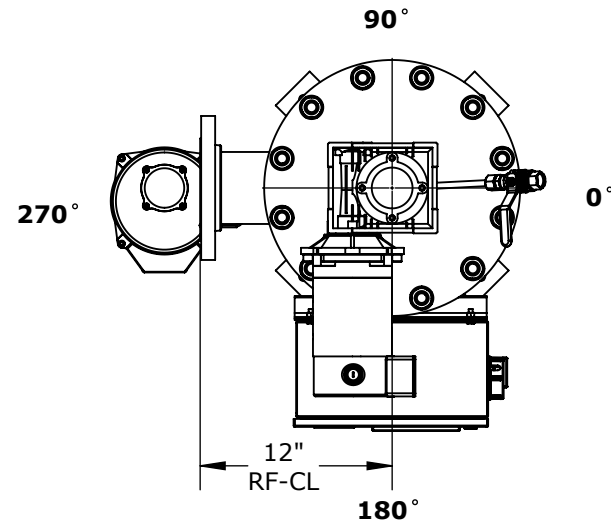

NOZZLE SCHEDULE			
MARK	QTY	SIZE / RATING	DESCRIPTION
N1	1	4" 150# RFSO	INLET
N2	1	4" 150# RFSO	OUTLET
N3	2	1/2" 3000# NPT	PRESSURE GAUGE
N4	1	1/4" NPT (THRU MECH SEAL)	VENT
N5	1		CLEAN DRAIN
N6	1	2" 3000# NPT	DIRTY DRAIN
VESSEL DESIGN CONDITIONS			
CODE: ASME SECTION VIII DIV. 1, 2021 EDITION			
M.A.W.P.:	150 PSI @ 200°F	M.D.M.T.:	-20° F @ 150 PSI
M.A.E.P.:	15 PSI @ 200°F		
CORROSION ALLOWANCE:	N/A	HYDROTEST PRESS:	195 PSI
STAMP:	UM	SERVICE:	NON LETHAL
PWHT:	N/A	RADIOGRAPHY:	N/A
MATERIAL:	SS304	GASKET:	SPIRAL WOUND

NOTES

1. UNIT SHIPS PRE-ASSEMBLED, TURN-KEY.
2. FLOW RATE UP TO 450gpm (WATER)
3. AVAILABLE SCREEN SIZES (MICRON)
 1. 50um, 100um, 200um, 500um, 1000um
4. TOUCH SCREEN CONTROL SYSTEM, WITH USB DATALOGGING.
5. INQUIRE FOR NO-CHARGE ADAPTERS (NPT, BSP,
6. CAM LOCK, OTHER FLANGE SIZES etc)
7. SHIPPING WEIGHT (WITH 4X4 PALLET): 400 LBS

<p>THIRD ANGLE PROJECTION TOLERANCES-UNLESS OTHERWISE NOTED</p> <p>DECIMAL .X = ±.1" .XX = ±.02" .XXX = ±.005"</p> <p>FRACTIONAL ±1/8"</p> <p>ANGULAR ±.1°</p> <p>MAX. MACHINED SURFACE FINISH 125√</p>	<p>FIL-TREK CORPORATION 55 Stafford Court Cambridge, Ontario N1T 2B3 Canada</p> <p>Phone: (519) 623-7448 Fax: (519) 623-8807 Email: info@fil-trek.com Website: www.fil-trek.com</p>				
	<p>THIS DRAWING IS THE PROPERTY OF 'FIL-TREK CORPORATION' AND MUST NOT BE COPIED OR USED IN ANY WAY DETRIMENTAL TO THE CORPORATION</p> <p>EQUIPMENT: AUTOMATED STRAINER</p> <p>MODEL NO: S498-4F-X-S6-PT2-L2</p> <p>CUSTOMER: STOCK</p>				
PARENT: NONE	DRAWN: MM	DATE: 2022-04-25	SERIAL No. V12979	PART. No. 003011-00051	REV. No. 0
CHK'D: TS	SCALE: NTS				