

NOZZLE SCHEDULE			
MARK	QTY	SIZE / RATING	DESCRIPTION
N1	1	2" CL3000 NPT	INLET
N2	1	2" CL3000 NPT	OUTLET
N3	2	1/2" CL3000 NPT	PRESSURE GAUGE
N4	1	1/2" CL3000 NPT	VENT
N5	1	2" CL3000 NPT	SPARE
N6	0		DIRTY DRAIN

VESSEL DESIGN CONDITIONS	
CODE:	ASME SECTION VIII DIV. 1, 2023 EDITION.
M.A.W.P.:	150 PSI @ 400°F
M.D.M.T.:	-20° F @ 150 PSI
M.A.W.P.:	FV PSI @ 400°F
CORROSION ALLOWANCE:	N/A
HYDROTEST PRESS:	210 PSI
STAMP:	UM/CRN# 9350.7C
SERVICE:	UNK. LIQUID NON LETHAL
PWHT:	N/A
RADIOGRAPHY:	N/A
MATERIAL:	CS
GASKET:	BUNA

NOTES:

1. VESSEL DRY WEIGHT: 147.0000 LBS.
2. SHIPPING WEIGHT: 177 LBS.
3. FLOODED WEIGHT: 216 LBS.
4. VESSEL VOLUME: 1.1 CU. FT.
5. VESSEL WILL HOUSE (QTY=1) SIZE TWO SS304 BASKET

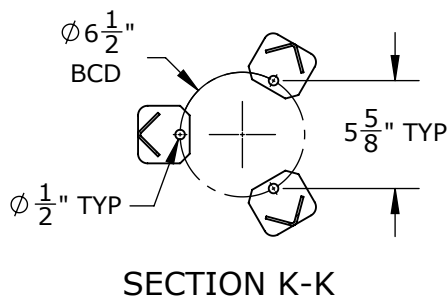
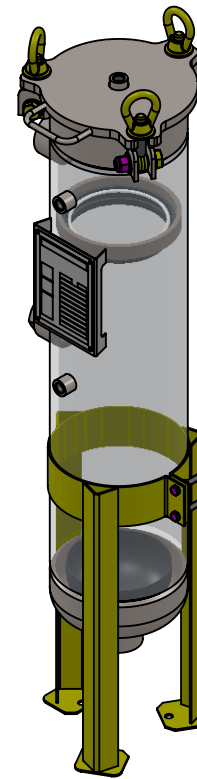
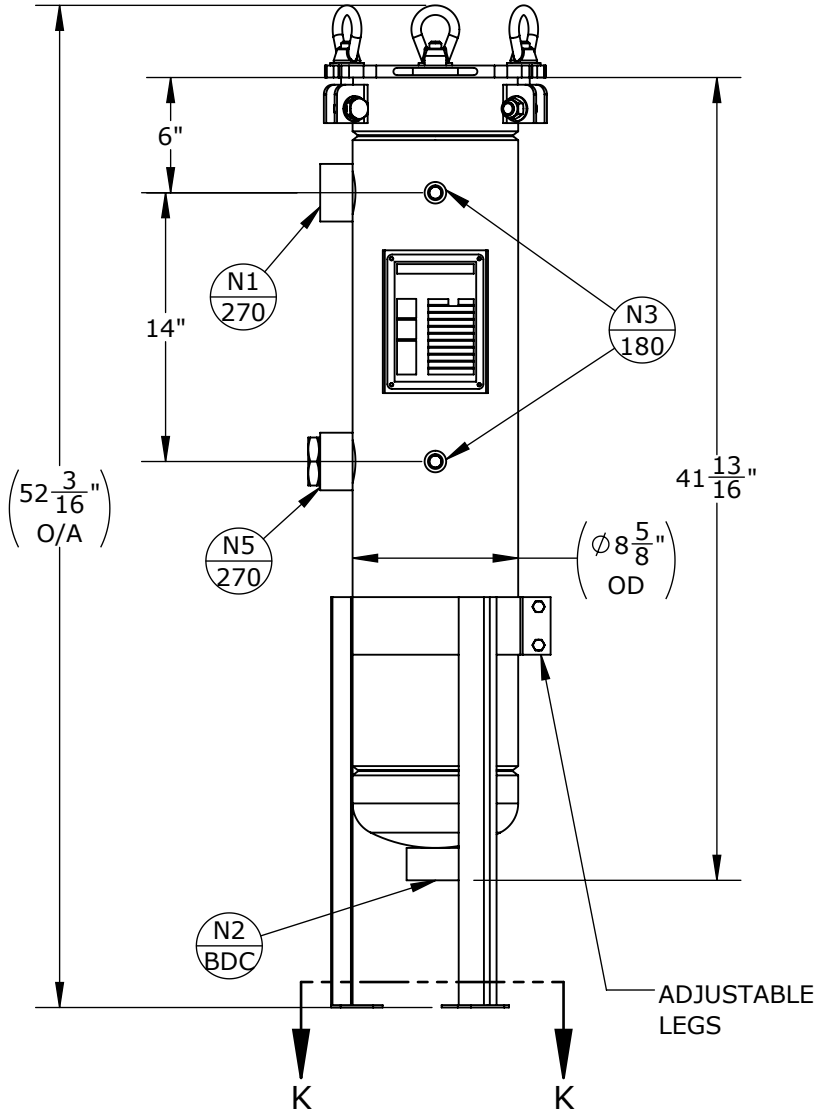

APPROVED WITH MARK-UPS <input type="checkbox"/>		APPROVED <input type="checkbox"/>	
 THIRD ANGLE PROJECTION	 FIL-TREK CORPORATION		
	55 Stafford Court Cambridge, Ontario N1T 1B3 Canada		
TOLERANCES-UNLESS OTHERWISE NOTED DECIMAL .X = ±.1" .XX = ±.02" .XXX = ±.005" FRACTIONAL = ±1/8" ANGULAR = ± 1° MAX. MACHINED SURFACE FINISH 125/√		Phone: (519) 623-7448 Fax: (519) 623-8807 Email: info@fil-trek.com Website: www.fil-trek.com	
THIS DRAWING IS THE PROPERTY OF 'FIL-TREK CORPORATION' AND MUST NOT BE COPIED OR USED IN ANY WAY DETRIMENTAL TO THE CORPORATION			
EQUIPMENT:		SL SERIES (SINGLE BAG FILTER VESSEL)	
MODEL NO:		SL112-2F-CDB-150	
CUSTOMER:			
PARENT: NONE	DRAWN: JG	DATE: 2024-03-27	SERIAL No. Part No. 002002-18546
	CHK'D: TS	SCALE: NTS	REV. No. 0