

NOZZLE SCHEDULE			
MARK	QTY	SIZE / RATING	DESCRIPTION
N1	1	4" RFSO CL150	INLET
N2	1	4" RFSO CL150	OUTLET
N3	2	1/2" NPT CL3000	PRESSURE GAUGE
N4	1	1/2" NPT CL3000	VENT
N5	1	1/2" NPT CL3000	CLEAN DRAIN
N6	0		DIRTY DRAIN

VESSEL DESIGN CONDITIONS	
CODE:	BEST COMMERCIAL PRACTICE
M.A.W.P.: 270 PSI @ 100°F	M.D.M.T.: -20°F @ 270 PSI
M.A.W.P.: FV PSI @ 100°F	HYDROTEST PRESS: 351 PSI
CORROSION ALLOWANCE: N/A	SERVICE: UNK. LIQUID, NON-LETHAL
STAMP: N/A	RADIOGRAPHY: N/A
PWHT: N/A	GASKET: <input type="checkbox"/> BUNA <input type="checkbox"/> VITON <input type="checkbox"/> EPDM
MATERIAL: CS	<input type="checkbox"/> OTHER: _____

<b>NOTES:</b> DRY WEIGHT: 170 LBS SHIPPING WEIGHT: 200 LBS VOLUME: 1 CU. FT. INTERNALS: 1 X SIZE 2 BAKSET	<b>FACTORY INSTALLED OPTIONS:</b> <input type="checkbox"/> STAINLESS STEEL BOLTING (SS316) <input type="checkbox"/> N3 DIFFERENTIAL PRESSURE GAUGE TYPE: _____ <input type="checkbox"/> N4 PRESSURE RELIEF VALVE TYPE: _____ <input type="checkbox"/> N4 AIR ELIMINATOR TYPE: _____ <input type="checkbox"/> N4 VENT VALVE <input type="checkbox"/> N5/N6 DRAIN VALVES
---	--

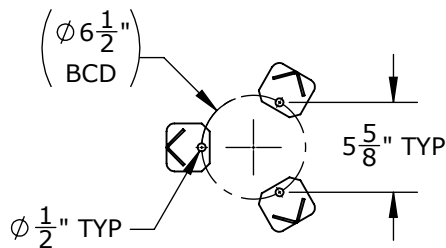
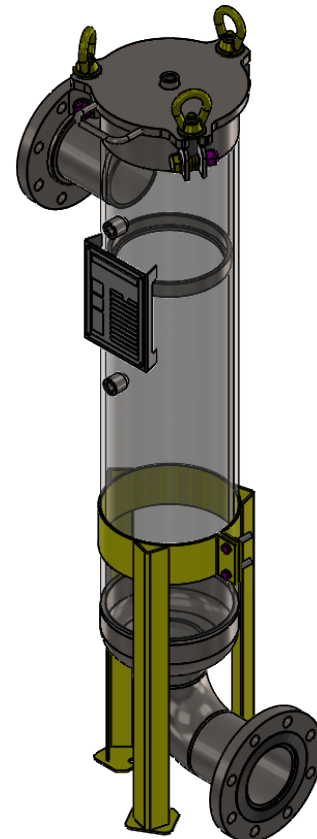
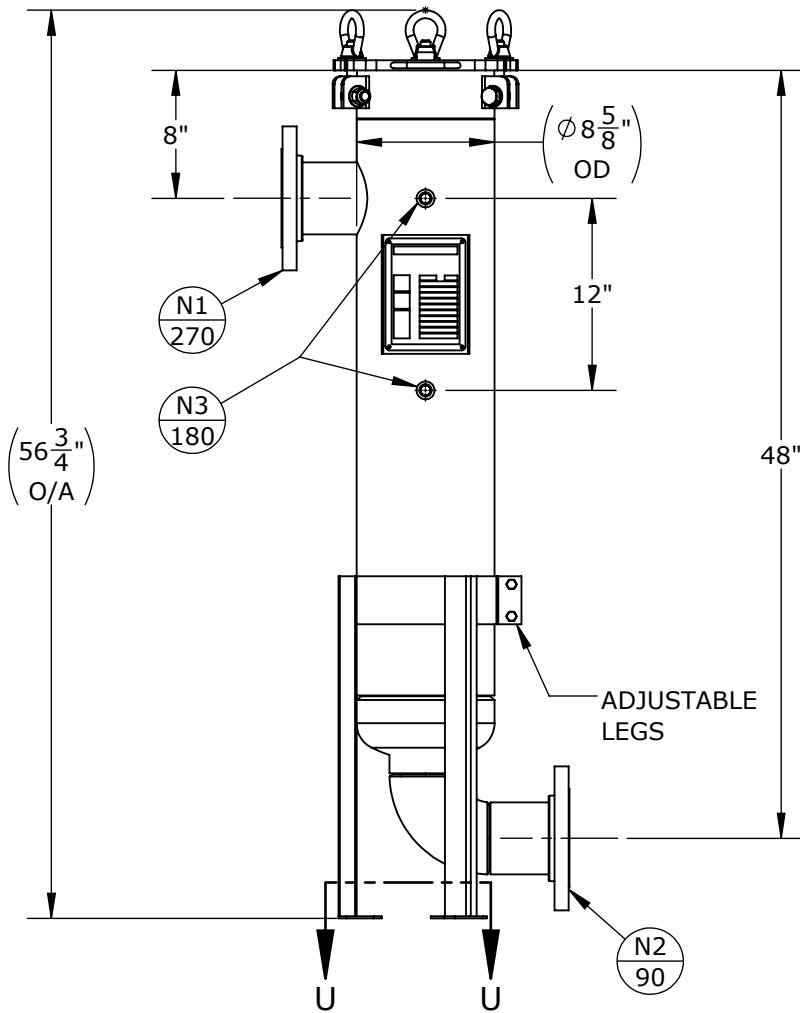

SECTION U-U  
SCALE 1 : 12

APPROVED WITH MARK-UPS  APPROVED

THIRD ANGLE PROJECTION
TOLERANCES-UNLESS OTHERWISE NOTED
DECIMAL .X = ±.1" .XX = ±.02" .XXX = ±.005"
FRACTIONAL = ±1/8"
ANGULAR = ± 1°
MAX. MACHINED SURFACE FINISH 125/√

**FIL-TREK CORPORATION**  
 55 Stafford Court  
 Cambridge, Ontario  
 N1T 1B3  
 Canada

Phone: (519) 623-7448  
 Fax: (519) 623-8807  
 Email: info@fil-trek.com  
 Website: www.fil-trek.com

THIS DRAWING IS THE PROPERTY OF 'FIL-TREK CORPORATION' AND MUST NOT BE COPIED OR USED IN ANY WAY DETRIMENTAL TO THE CORPORATION

EQUIPMENT: ESL SERIES (BAG FILTER VESSEL)  
 MODEL NO: ESL112-4F-E-270

VESSEL QUANTITY:	DRAWN: CL	DATE: 2020-03-05	SERIAL No.	Part No. 002001-00337	REV. No. 0
	CHK'D: AJ	SCALE: NTS			