

NOZZLE SCHEDULE			
MARK	QTY	SIZE / RATING	DESCRIPTION
N1	1	4" RFSO CL150	INLET
N2	1	4" RFSO CL150	OUTLET
N3	2	1/2" NPT CL3000	PRESSURE GAUGE
N4	1	1/2" NPT CL3000	VENT
N5	1	1/2" NPT CL3000	CLEAN DRAIN
N6	0		DIRTY DRAIN

VESSEL DESIGN CONDITIONS	
CODE:	BEST COMMERCIAL PRACTICE
M.A.W.P.: 150 PSI @ 400°F	M.D.M.T.: -20°F @ 150 PSI
M.A.W.P.: FV PSI @ 400°F	HYDROTEST PRESS: 195 PSI
CORROSION ALLOWANCE: N/A	SERVICE: UNK. LIQUID, NON-LETHAL
STAMP: N/A	RADIOGRAPHY: N/A
PWHT: N/A	GASKET: <input type="checkbox"/> BUNA <input type="checkbox"/> VITON <input type="checkbox"/> EPDM
MATERIAL: SS304	<input type="checkbox"/> OTHER: _____

**NOTES:**  
 DRY WEIGHT: 140 LBS  
 SHIPPING WEIGHT: 170 LBS  
 VOLUME: 0.75 CU. FT.  
 INTERNALS: 1 X SIZE 1 BAKSET

- FACTORY INSTALLED OPTIONS:**
- STAINLESS STEEL BOLTING (SS316)
  - N3 DIFFERENTIAL PRESSURE GAUGE TYPE: \_\_\_\_\_
  - N4 PRESSURE RELIEF VALVE TYPE: \_\_\_\_\_
  - N4 AIR ELIMINATOR TYPE: \_\_\_\_\_
  - N4 VENT VALVE
  - N5/N6 DRAIN VALVES

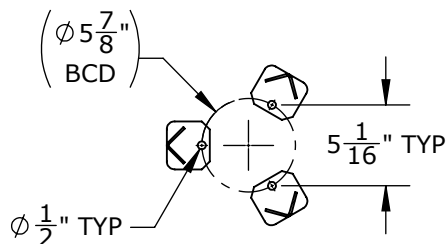
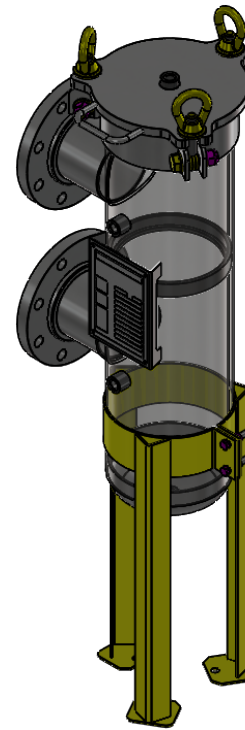
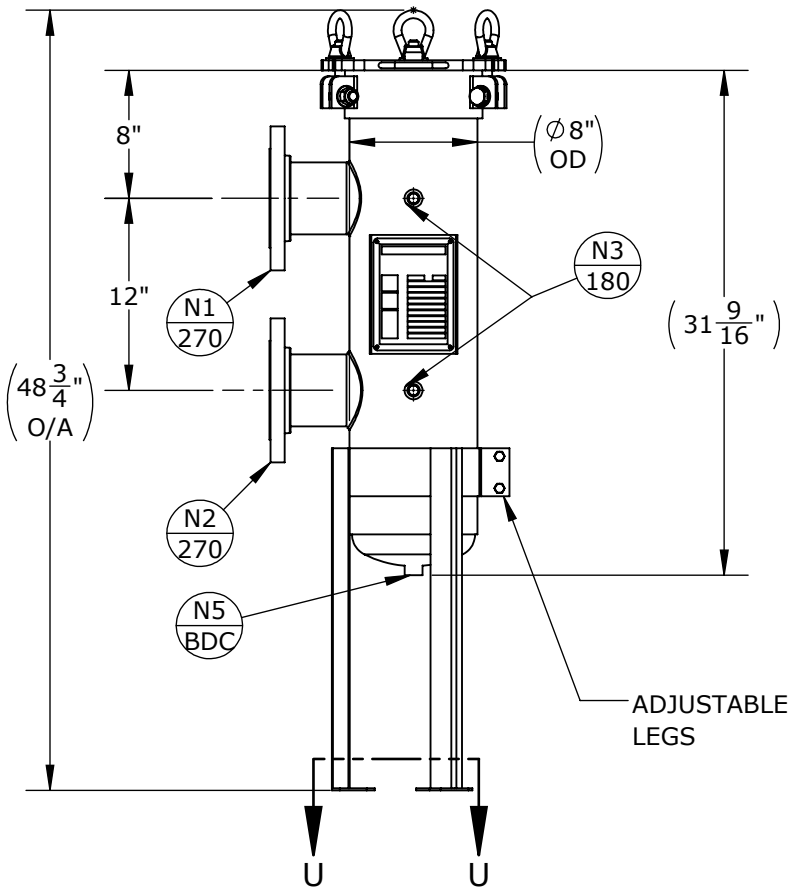

SECTION U-U  
SCALE 1 : 12

APPROVED WITH MARK-UPS  APPROVED

THIRD ANGLE PROJECTION  
 TOLERANCES-UNLESS OTHERWISE NOTED  
 DECIMAL .X = ±.1" .XX = ±.02" .XXX = ±.005"  
 FRACTIONAL = ±1/8"  
 ANGULAR = ± 1°  
 MAX. MACHINED SURFACE FINISH 125/√

**FIL-TREK CORPORATION**  
 55 Stafford Court  
 Cambridge, Ontario  
 N1T 1B3  
 Canada  
 Phone: (519) 623-7448  
 Fax: (519) 623-8807  
 Email: info@fil-trek.com  
 Website: www.fil-trek.com

THIS DRAWING IS THE PROPERTY OF 'FIL-TREK CORPORATION' AND MUST NOT BE COPIED OR USED IN ANY WAY DETRIMENTAL TO THE CORPORATION

EQUIPMENT:	ESL SERIES (BAG FILTER VESSEL)		
MODEL NO:	S4ESL111-4F-DB-150		
CUSTOMER:			
VESSEL QUANTITY:	DRAWN: CL	DATE: 2020-03-05	SERIAL No. Part No. 002001-00164
	CHK'D: AJ	SCALE: NTS	REV. No. 0