

NOZZLE SCHEDULE			
MARK	QTY	SIZE / RATING	DESCRIPTION
N1	1	4" RFSO CL150	INLET
N2	1	4" RFSO CL150	OUTLET
N3	2	1/2" NPT CL3000	PRESSURE GAUGE
N4	1	1/2" NPT CL3000	VENT
N5	1	1/2" NPT CL3000	CLEAN DRAIN
N6	0		DIRTY DRAIN

VESSEL DESIGN CONDITIONS

CODE: BEST COMMERCIAL PRACTICE	
M.A.W.P.: 270 PSI @ 100°F	M.D.M.T.: -20°F @ 270 PSI
M.A.W.P.: FV PSI @ 100°F	HYDROTEST PRESS: 351 PSI
CORROSION ALLOWANCE: N/A	SERVICE: UNK. LIQUID, NON-LETHAL
STAMP: N/A	RADIOGRAPHY: N/A
PWHT: N/A	GASKET: <input type="checkbox"/> BUNA <input type="checkbox"/> VITON <input type="checkbox"/> EPDM
MATERIAL: SS316	<input type="checkbox"/> OTHER: _____

- NOTES:**
 DRY WEIGHT: 170 LBS
 SHIPPING WEIGHT: 200 LBS
 VOLUME: 1 CU. FT.
 INTERNALS: 1 X SIZE 2 BAKSET
- FACTORY INSTALLED OPTIONS:**
 STAINLESS STEEL BOLTING (SS316)
 N3 DIFFERENTIAL PRESSURE GAUGE TYPE: _____
 N4 PRESSURE RELIEF VALVE TYPE: _____
 N4 AIR ELIMINATOR TYPE: _____
 N4 VENT VALVE
 N5/N6 DRAIN VALVES

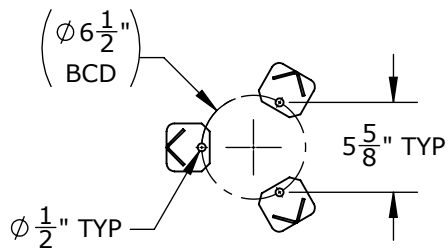
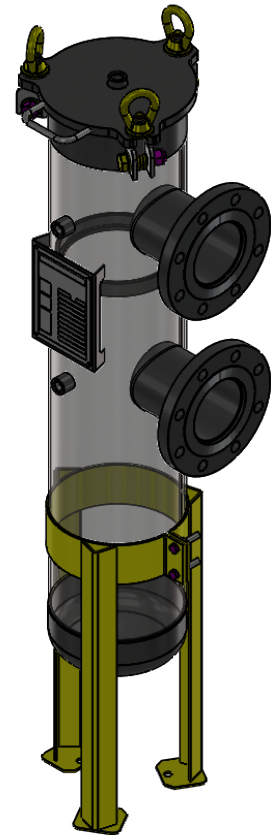
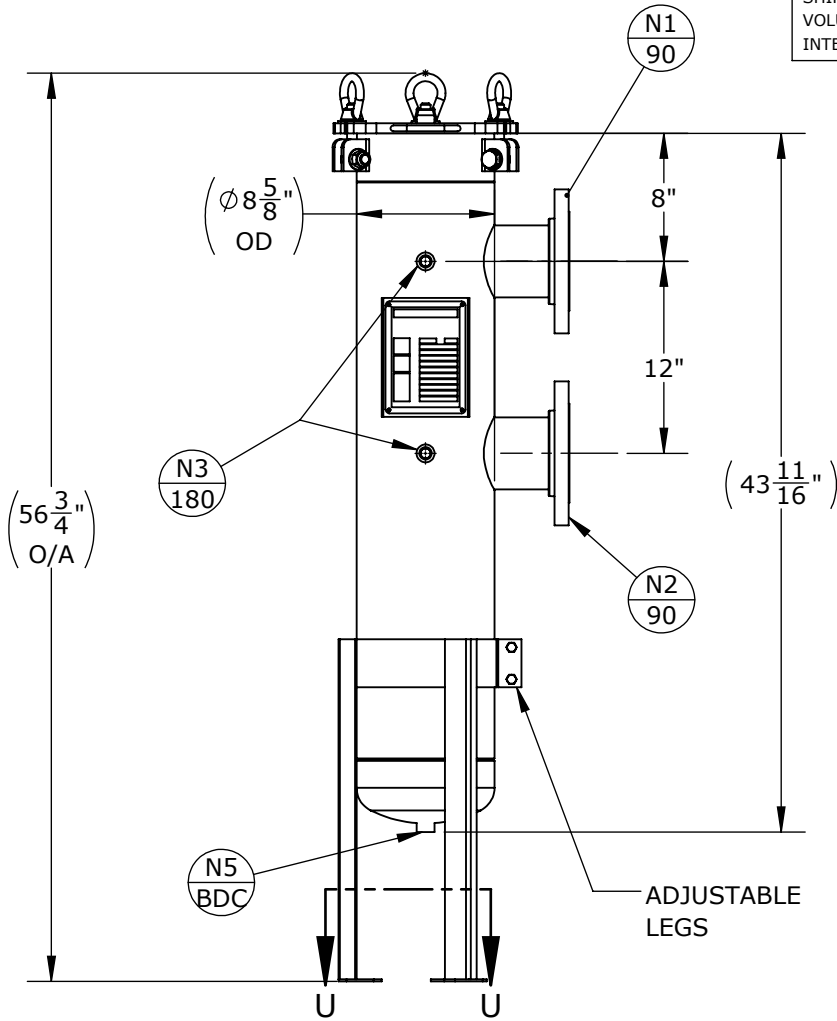

SECTION U-U
SCALE 1 : 12

APPROVED WITH MARK-UPS APPROVED

THIRD ANGLE PROJECTION
 TOLERANCES-UNLESS OTHERWISE NOTED
 DECIMAL .X = ±.1" .XX = ±.02" .XXX = ±.005"
 FRACTIONAL = ±1/8"
 ANGULAR = ± 1°
 MAX. MACHINED SURFACE FINISH 125/√

FIL-TREK CORPORATION
 55 Stafford Court
 Cambridge, Ontario
 N1T 1B3
 Canada
 Phone: (519) 623-7448
 Fax: (519) 623-8807
 Email: info@fil-trek.com
 Website: www.fil-trek.com

THIS DRAWING IS THE PROPERTY OF 'FIL-TREK CORPORATION' AND MUST NOT BE COPIED OR USED IN ANY WAY DETRIMENTAL TO THE CORPORATION

EQUIPMENT: ESL SERIES (BAG FILTER VESSEL)
 MODEL NO: S6ESL112-4F-DA-270
 CUSTOMER:

VESSEL QUANTITY:	DRAWN: CL	DATE: 2020-03-05	SERIAL No.	Part No. 002001-00318	REV. No. 0
	CHK'D: AJ	SCALE: NTS			