

SECTION K-K

NOZZLE SCHEDULE

MARK	QTY	SIZE / RATING	DESCRIPTION
N1	1	2" 3000# NPT	INLET
N2	1	2" 3000# NPT	OUTLET
N3	2	1/2" 3000# NPT	PRESSURE GAUGE
N4	1	1/2" 3000# NPT	VENT
N5	1	1/2" 3000# NPT	CLEAN DRAIN
N6	0	-	DIRTY DRAIN

VESSEL DESIGN CONDITIONS

CODE: ASME SECTION VIII DIV. 1, 2015 EDITION	
M.A.W.P.: 150 PSI @ 250°F	M.D.M.T.: -20° F @ 150 PSI
M.A.W.P.: FV PSI @ 250°F	
CORROSION ALLOWANCE: NONE	HYDROTEST PRESS: 195 PSI
STAMP: UM	SERVICE: NONE
PWHT: N/A	RADIOGRAPHY: N/A
MATERIAL: SS304	GASKET: BUNA

NOTES:

1. VESSEL WILL HOUSE (QTY=1) DOUBLE LENGTH BASKET.
2. DRY WEIGHT: 82.75 LBS
3. FLOODED WEIGHT: 130 LBS
4. SHIPPING WEIGHT: 120 LBS
5. VESSEL VOLUME: 1 FT³

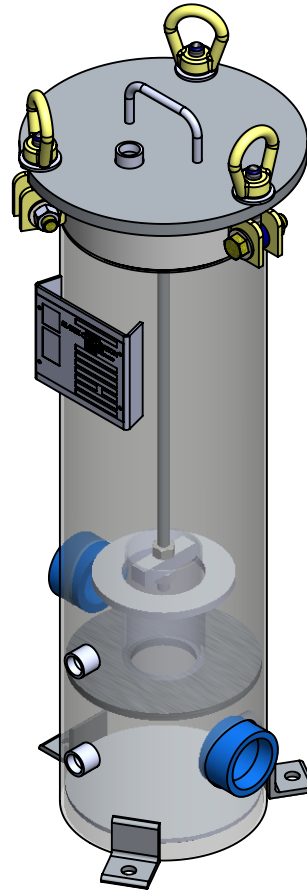

<p>THIRD ANGLE PROJECTION</p>	<p>FIL-TREK CORPORATION</p>	
	<p>55 Stafford Court Cambridge, Ontario N1T 1B3 Canada</p> <p>Phone: (519) 623-7448 Fax: (519) 623-8807 Email: info@fil-trek.com Website: www.fil-trek.com</p>	
<p>THIS DRAWING IS THE PROPERTY OF 'FIL-TREK CORPORATION' AND MUST NOT BE COPIED OR USED IN ANY WAY DETRIMENTAL TO THE CORPORATION</p>		
<p>EQUIPMENT: CARTRIDGE FILTER VESSEL (VF SERIES)</p>		
<p>MODEL NO: S4VF08-01-618-2P-150</p>		
<p>CUSTOMER:</p>		
PARENT: NEW DESIGN	DRAWN: JC	DATE: 03/05/2017
CHK'D: VD	SCALE: NTS	SERIAL No. Part No. 001020-00021
		REV. No. 0