

NOZZLE SCHEDULE			
MARK	QTY	SIZE / RATING	DESCRIPTION
N1	1	8" 150# RFSO	INLET
N2	1	8" 150# RFSO	OUTLET
N3	2	1/2" 3000# NPT	PRESSURE GAUGE
N4	1	1/2" 3000# NPT	VENT
N5	1	2" 3000# NPT	CLEAN DRAIN
N6	1	2" 3000# NPT	DIRTY DRAIN

VESSEL DESIGN CONDITIONS	
CODE:	ASME SECTION VIII DIV. 1, 2015 EDITION
M.A.W.P.:	150 PSI @ 250°F
M.D.M.T.:	-20° F @ 150 PSI
M.A.E.P.:	15 PSI @ 250°F
CORROSION ALLOWANCE:	NONE
HYDROTEST PRESS:	195 PSI
STAMP:	UM
SERVICE:	NON LETHAL
PWHT:	N/A
RADIOGRAPHY:	N/A
MATERIAL:	2507
GASKET:	BUNA

NOTES:

- VESSEL DRY WEIGHT: 628.36 LBS.
- SHIPPING WEIGHT: 650 LBS.
- FLOODED WEIGHT: 1510 LBS.
- VESSEL VOLUME: 12.6 FT³
- VESSEL WILL HOUSE (QTY=52) 2.5"OD x 40" LG DOE CARTRIDGE.

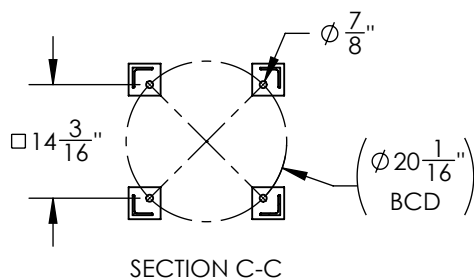
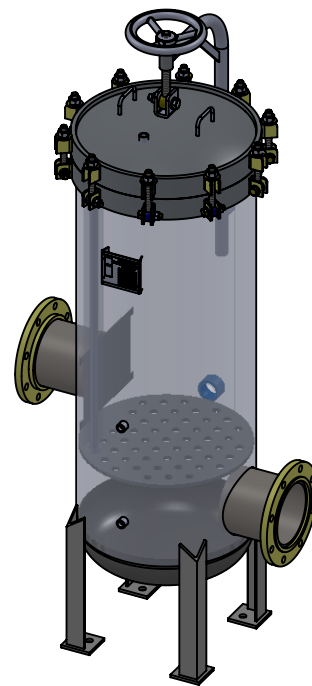
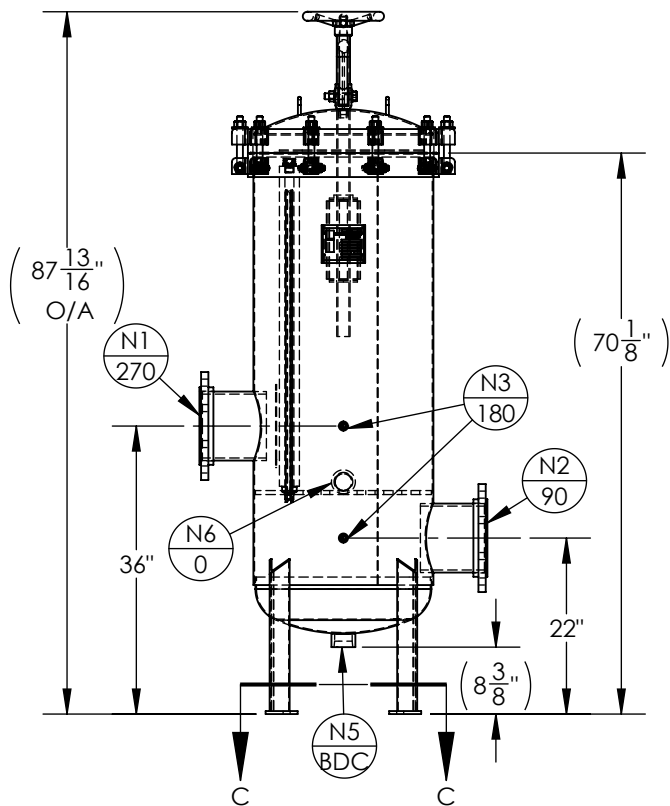

APPROVED WITH MARK-UPS <input type="checkbox"/>		APPROVED <input type="checkbox"/>	
 THIRD ANGLE PROJECTION		 FIL-TREK CORPORATION	
TOLERANCES-UNLESS OTHERWISE NOTED DECIMAL .X = ±.1" .XX = ±.02" .XXX = ±.005" FRACTIONAL = ±1/8" ANGULAR = ± 1° MAX. MACHINED SURFACE FINISH 125/√		55 Stafford Court Cambridge, Ontario N1T 1B3 Canada Phone: (519) 623-7448 Fax: (519) 623-8807 Email: info@fil-trek.com Website: www.fil-trek.com	
THIS DRAWING IS THE PROPERTY OF 'FIL-TREK CORPORATION' AND MUST NOT BE COPIED OR USED IN ANY WAY DETRIMENTAL TO THE CORPORATION			
EQUIPMENT:		CARTRIDGE (GL SERIES)	
MODEL NO:		2507GL22-052-4-8F-150	
CUSTOMER:			
PARENT: NEW DESIGN	DRAWN: MS	DATE: 8/2/2017	SERIAL No. Part No. 001001-00353
CHK'D:	SCALE: NTS		REV. No. 0