

NOZZLE SCHEDULE			
MARK	QTY	SIZE / RATING	DESCRIPTION
N1	1	1" 3000# NPT	INLET
N2	1	1" 3000# NPT	OUTLET
N3	2	1/2" 3000# NPT	PRESSURE GAUGE
N4	1	1/2" 3000# NPT	VENT
N5	1	1" 3000# NPT	CLEAN DRAIN
N6	1	1" 3000# NPT	DIRTY DRAIN

VESSEL DESIGN CONDITIONS			
CODE: ASME SECTION VIII DIV. 1, 2015 EDITION			
M.A.W.P.:	150 PSI @ 400°F	M.D.M.T.:	-20° F @ 150 PSI
M.A.W.P.:	FV PSI @ 400°F		
CORROSION ALLOWANCE:	NONE	HYDROTEST PRESS:	195 PSI
STAMP:	UM	SERVICE:	NON LETHAL
PWHT:	N/A	RADIOGRAPHY:	N/A
MATERIAL:	CS	GASKET:	BUNA

- NOTES:
- DRY WEIGHT: 39.41 LBS
 - FLOODED WEIGHT: 100 LBS
 - SHIPPING WEIGHT: 100 LBS
 - VESSEL VOLUME: 0.4 FT³
 - VESSEL WILL HOUSE (QTY=1) 2.75" OD x 20" LG CARTRIDGE

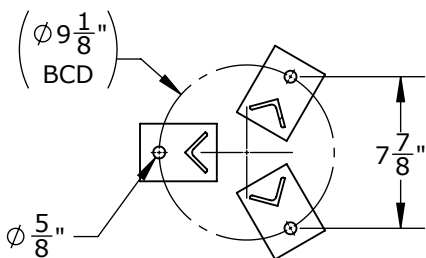
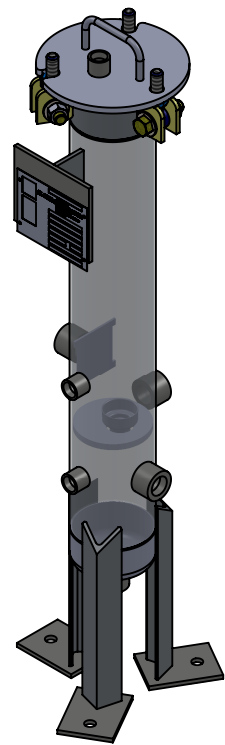
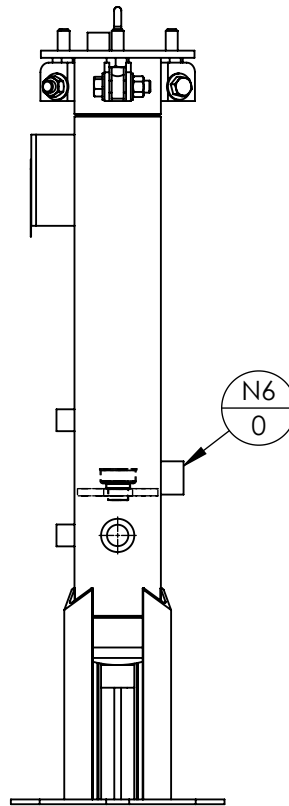
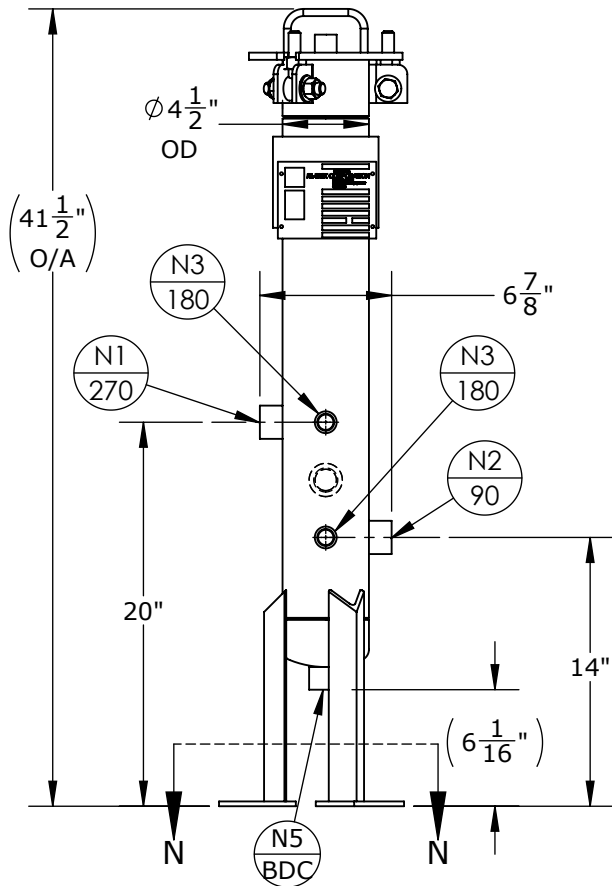

SECTION N-N
SCALE 1 : 10

APPROVED WITH MARK-UPS <input type="checkbox"/>		APPROVED <input type="checkbox"/>	
 THIRD ANGLE PROJECTION TOLERANCES-UNLESS OTHERWISE NOTED DECIMAL .X = ±.1" .XX = ±.02" .XXX = ±.005" FRACTIONAL = ±1/8" ANGULAR = ± 1° MAX. MACHINED SURFACE FINISH 125/√	 FIL-TREK CORPORATION 55 Stafford Court Cambridge, Ontario N1T 1B3 Canada Phone: (519) 623-7448 Fax: (519) 623-8807 Email: info@fil-trek.com Website: www.fil-trek.com		
	THIS DRAWING IS THE PROPERTY OF 'FIL-TREK CORPORATION' AND MUST NOT BE COPIED OR USED IN ANY WAY DETRIMENTAL TO THE CORPORATION EQUIPMENT: CARTRIDGE FILTER VESSEL MODEL NO: GL04-001-2-1P-150 CUSTOMER:		
PARENT: NEW DESIGN	DRAWN: GB	DATE: 27/06/2017	SERIAL No. Part No. 001001-00366
CHK'D:	SCALE: NTS		REV. No. 0