

SECTION K-K

| NOZZLE SCHEDULE |     |                |                |
|-----------------|-----|----------------|----------------|
| MARK            | QTY | SIZE / RATING  | DESCRIPTION    |
| N1              | 1   | 4" 150# RFSO   | INLET          |
| N2              | 1   | 4" 150# RFSO   | OUTLET         |
| N3              | 2   | 1/2" 3000# NPT | PRESSURE GAUGE |
| N4              | 1   | 1/2" 3000# NPT | VENT           |
| N5              | 1   | 1" 3000# NPT   | CLEAN DRAIN    |
| N6              | 1   | 1" 3000# NPT   | DIRTY DRAIN    |

| VESSEL DESIGN CONDITIONS |  |
|--------------------------|--|
| CODE:                    | ASME SECTION VIII DIV. 1, 2015 EDITION     |
| M.A.W.P.:                | 150 PSI @ 400°F M.D.M.T.: -20° F @ 150 PSI |
| M.A.W.P.:                | FV PSI @ 400°F                             |
| CORROSION ALLOWANCE:     | NONE HYDROTEST PRESS: 195 PSI              |
| STAMP:                   | U SERVICE: NON LETHAL                      |
| PWHT:                    | N/A RADIOGRAPHY: N/A                       |
| MATERIAL:                | SS304 GASKET: BUNA-N                       |

NOTES:

1. VESSEL DRY WEIGHT: **354 LBS.**
2. SHIPPING WEIGHT: **500 LBS.**
3. FLOODED WEIGHT: **755 LBS.**
4. VESSEL VOLUME: **6.5 CU. FT.**
5. VESSEL WILL HOUSE (QTY=25) 2.5"OD x 40" LG CARTRIDGE.

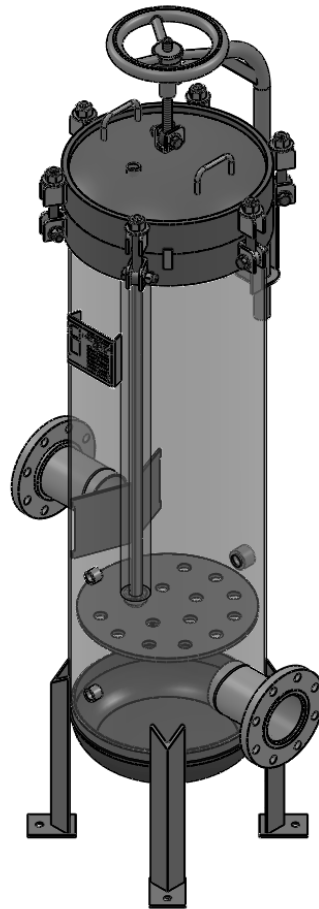

|   |            |  |                                  |
|---|------------|--|----------------------------------|
| APPROVED WITH MARK-UPS <input type="checkbox"/>   |            | APPROVED <input type="checkbox"/>  |                                  |
| <p>THIRD ANGLE PROJECTION</p>   |            | <p><b>FIL-TREK CORPORATION</b></p>   |                                  |
| <p>TOLERANCES-UNLESS OTHERWISE NOTED</p> <p>DECIMAL .X = ±.1" .XX = ±.02" .XXX = ±.005"</p> <p>FRACTIONAL = ±1/8"</p> <p>ANGULAR = ± 1°</p> <p>MAX. MACHINED SURFACE FINISH 125/√</p> |            | <p>55 Stafford Court<br/>Cambridge, Ontario<br/>N1T 1B3<br/>Canada</p> <p>Phone: (519) 623-7448<br/>Fax: (519) 623-8807<br/>Email: info@fil-trek.com<br/>Website: www.fil-trek.com</p> |                                  |
| THIS DRAWING IS THE PROPERTY OF 'FIL-TREK CORPORATION' AND MUST NOT BE COPIED OR USED IN ANY WAY DETRIMENTAL TO THE CORPORATION   |            |  |                                  |
| EQUIPMENT:  |            | GL SERIES (CARTRIDGE FILTER VESSEL)  |                                  |
| MODEL NO:   |            | S4GL16-025-4-4F-150  |                                  |
| CUSTOMER:   |            |  |                                  |
| PARENT: NEW   | DRAWN: JN  | DATE: 13/06/2017   | SERIAL No. Part No. 001001-00357 |
| CHK'D:  | SCALE: NTS |  | REV. No. 0                       |