

NOZZLE SCHEDULE			
MARK	QTY	SIZE / RATING	DESCRIPTION
N1	1	2" 150# RFSO	INLET
N2	1	2" 150# RFSO	OUTLET
N3	2	1/2" 3000# NPT	PRESSURE GAUGE
N4	1	1/2" 3000# NPT	VENT
N5	1	1" 3000# NPT	CLEAN DRAIN
N6	1	1" 3000# NPT	DIRTY DRAIN

VESSEL DESIGN CONDITIONS	
CODE:	ASME SECTION VIII DIV. 1, 2015 EDITION
M.A.W.P.:	150 PSI @ 400°F
M.D.M.T.:	-20° F @ 150 PSI
M.A.W.P.:	FV PSI @ 400°F
CORROSION ALLOWANCE:	NONE
HYDROTEST PRESS:	195 PSI
STAMP:	UM
SERVICE:	-
PWHT:	N/A
RADIOGRAPHY:	NONE
MATERIAL:	SS316
GASKET:	BUNA

- NOTES:
1. VESSEL WILL HOUSE (QTY=6) 2.5" OD x 40" LG CARTRIDGES.
 2. DRY WEIGHT: 120.35 LBS
 3. FLOODED WEIGHT: 235 LBS
 4. SHIPPING WEIGHT: 200 LBS
 5. VESSEL VOLUME: 1.60 FT³

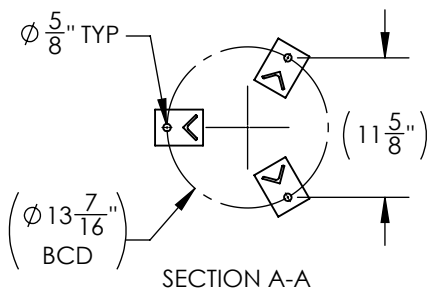
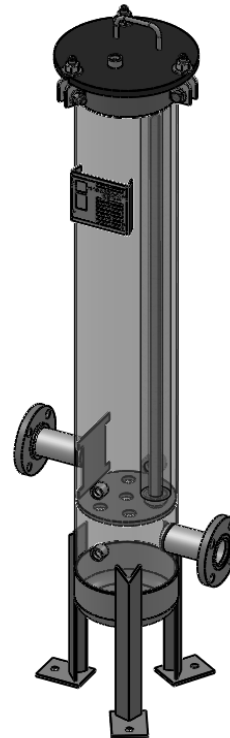
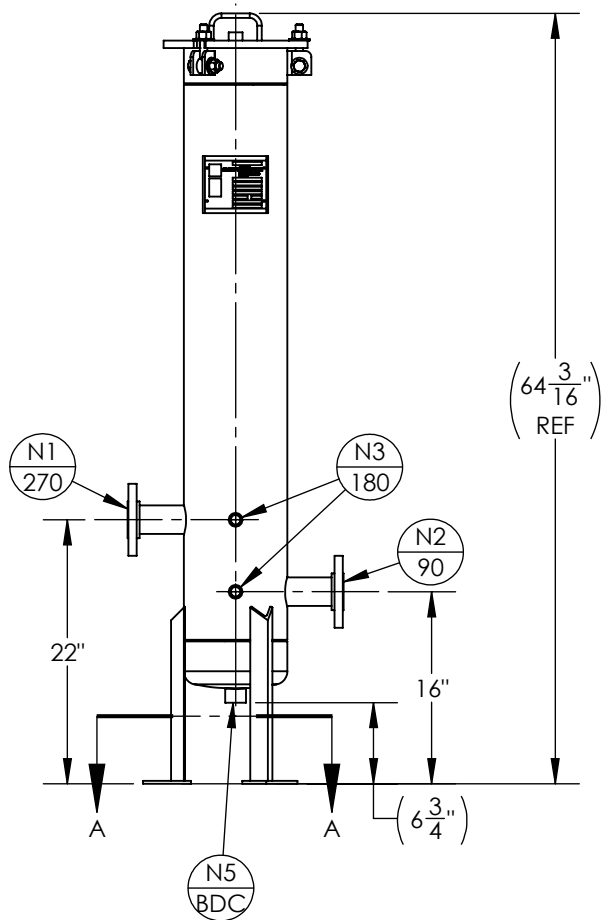

APPROVED WITH MARK-UPS APPROVED

<p>THIRD ANGLE PROJECTION</p> <p>TOLERANCES-UNLESS OTHERWISE NOTED</p> <p>DECIMAL .X = ±.1" .XX = ±.02" .XXX = ±.005"</p> <p>FRACTIONAL = ±1/8"</p> <p>ANGULAR = ± 1°</p> <p>MAX. MACHINED SURFACE FINISH 125/√</p>	<p>FIL-TREK CORPORATION</p> <p>55 Stafford Court Cambridge, Ontario N1T 1B3 Canada</p> <p>Phone: (519) 623-7448 Fax: (519) 623-8807 Email: info@fil-trek.com Website: www.fil-trek.com</p>				
	<p>THIS DRAWING IS THE PROPERTY OF 'FIL-TREK CORPORATION' AND MUST NOT BE COPIED OR USED IN ANY WAY DETRIMENTAL TO THE CORPORATION</p> <p>EQUIPMENT: GL SERIES (CARTRIDGE FILTER VESSEL)</p> <p>MODEL NO: S6GL08-006-4-2F-150</p> <p>CUSTOMER:</p>				
PARENT:	DRAWN: JN	DATE: 09/06/2017	SERIAL No.	Part No. 001001-00188	REV. No.
CHK'D:	SCALE: NTS				