

NOZZLE SCHEDULE			
MARK	QTY	SIZE / RATING	DESCRIPTION
N1	1	8"150# RFSO	INLET
N2	1	8"150# RFSO	OUTLET
N3	2	1/2" 3000# NPT	PRESSURE GAUGE
N4	1	1/2" 3000# NPT	VENT
N5	1	2" 3000# NPT	CLEAN DRAIN
N6	1	2" 3000# NPT	DIRTY DRAIN
VESSEL DESIGN CONDITIONS			
CODE: ASME SECTION VIII DIV. 1, 2015 EDITION			
M.A.W.P.: 150 PSI @ 400°F		M.D.M.T.: -20° F @ 150 PSI	
M.A.W.P.: FV PSI @ 400°F			
CORROSION ALLOWANCE: NONE		HYDROTEST PRESS: 195 PSI	
STAMP: U		SERVICE: NON LETHAL	
PWHT: N/A		RADIOGRAPHY: N/A	
MATERIAL: SS316		GASKET: BUNA	

NOTES:

- VESSEL DRY WEIGHT: 522.13 LBS.
- SHIPPING WEIGHT: 700 LBS.
- FLOODED WEIGHT: 1330 LBS.
- VESSEL VOLUME: 13.20 FT<sup>3</sup>
- VESSEL WILL HOUSE (QTY=52) 2.5"OD x 40" LG DOE CARTRIDGE.

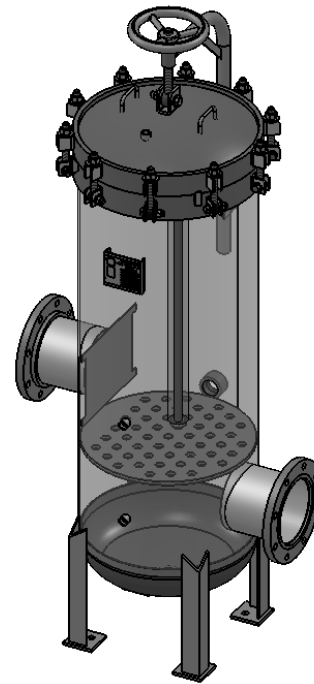

APPROVED WITH MARK-UPS <input type="checkbox"/>		APPROVED <input type="checkbox"/>	
<p>THIRD ANGLE PROJECTION</p>		<p><b>FIL-TREK CORPORATION</b></p>	
<p>TOLERANCES-UNLESS OTHERWISE NOTED</p> <p>DECIMAL .X = ±.1" .XX = ±.02" .XXX = ±.005"</p> <p>FRACTIONAL = ±1/8"</p> <p>ANGULAR = ± 1°</p> <p>MAX. MACHINED SURFACE FINISH 125/√</p>		<p>55 Stafford Court Cambridge, Ontario N1T 1B3 Canada</p> <p>Phone: (519) 623-7448 Fax: (519) 623-8807 Email: info@fil-trek.com Website: www.fil-trek.com</p>	
THIS DRAWING IS THE PROPERTY OF 'FIL-TREK CORPORATION' AND MUST NOT BE COPIED OR USED IN ANY WAY DETRIMENTAL TO THE CORPORATION			
EQUIPMENT: GL SERIES (CARTRIDGE FILTER VESSEL)		MODEL NO: S6GL22-052-4-8F-150	
CUSTOMER:			
PARENT: NEW DESIGN	DRAWN: JN	DATE: 19/06/2017	SERIAL No. Part No. 001001-00339
CHK'D:	SCALE: NTS		REV. No. 0